

# P161 SANITARY PRESSURE REDUCING VALVES

## INSTALLATION AND MAINTENANCE INSTRUCTIONS

---



## GENERAL INFORMATION

- These instructions must be carefully read before performing any work involving VALSTEAM ADCA products. Failure to observe these instructions may result in hazardous situations.
- These instructions describe the entire life cycle of the product. Keep them in a location that is accessible to every user and make these instructions available to every new owner of the product.
- Current regional and plant safety regulations must be considered and followed during installation, operation, and maintenance work.
- The images shown in these instructions are for illustration purposes only.
- For problems that cannot be solved with the help of these instructions, please contact VALSTEAM ADCA or its representative.

### VALSTEAM ADCA ENGINEERING S.A

Zona Ind.da Guia  
Pav.14 - Brejo  
3105-467 Guia, Pombal  
PORTUGAL  
quality@valsteam.com

We reserve the right to change the design and material of this product without notice.

# CONTENT

<b>1. SAFETY INFORMATION</b>	<b>4</b>
1.1. Explanation of symbols	4
1.2. Intended use	4
1.3. Qualification of personnel	5
1.4. Personal protective equipment	5
1.5. The system	5
1.6. ATEX	6
1.7. General safety notes	6
<b>2. PRODUCT INFORMATION</b>	<b>8</b>
2.1. Principle of operation	8
2.2. Certification	9
2.3. Product identification	10
2.4. Technical data	10
2.5. Factory assembly and cleaning	10
<b>3. TRANSPORT, STORAGE, AND PACKAGING</b>	<b>11</b>
<b>4. INSTALLATION</b>	<b>12</b>
4.1. Preparation for installation	13
4.2. Installation procedure	14
<b>5. START-UP</b>	<b>15</b>
5.1. Preparation for start-up	15
5.2. Start-up procedure	15
<b>6. OPERATION</b>	<b>16</b>
6.1. Using the CIP/SIP locking system	17
<b>7. SHUTDOWN</b>	<b>17</b>
7.1. Shutdown procedure	17
<b>8. PARTS LIST</b>	<b>18</b>
<b>9. MAINTENANCE</b>	<b>20</b>
9.1. Maintenance procedure	20
9.2. Replacing plug assembly and diaphragms	20
9.3. Tightening torques	21
<b>10. TROUBLESHOOTING</b>	<b>22</b>
<b>11. DISPOSAL</b>	<b>23</b>
<b>12. RETURNING PRODUCTS</b>	<b>23</b>

# 1. SAFETY INFORMATION

## 1.1. Explanation of symbols



### DANGER

Hazardous situations which, if not avoided by applying the correct preventive measures, will result in fatal or serious injury and/or considerable property damage.



### WARNING

Hazardous situations which, if not avoided by applying the correct preventive measures, could result in fatal or serious injury and/or considerable property damage.



### CAUTION

Hazardous situations which, if not avoided by applying the correct preventive measures, could result in moderately severe or minor injury.



### NOTICE

Situations which, if not avoided, can result in property damage or product malfunction.



### NOTE

Indicates additional information, tips, and recommendations.

## 1.2. Intended use

Refer to the markings on the device, such as nameplate and laser markings, Information Sheet (IS), and these Installation and Maintenance Instructions (IMI) to check that the product was designed for the intended use and meets the specifications used for sizing and selection. This includes checking application, material suitability, process medium, pressure, and temperature as well as their respective limiting values.

VALSTEAM ADCA does not assume any responsibility for damage resulting from inappropriate use of the product, damage caused by external stresses, or any other external factors. Correct installation of the product is the full responsibility of the contractor.

Inappropriate use of the product is any use other than the one described in this chapter.

Inappropriate use also includes:

- Use of spare parts that are not genuine;
- Performance of maintenance work not described in these instructions;
- Use outside the limits defined by the accessories connected to the product.
- Unauthorized modifications to the product.

If the product is to be used for an application or with a fluid other than the one it was designed for, contact VALSTEAM ADCA.

### 1.3. Qualification of personnel

Handling, installation, operation, and maintenance work must be carried out by fully trained and qualified personnel, capable of judging the work which they are assigned to perform and recognizing potentially hazardous situations. They should be trained to properly use this product according to these Installation and Maintenance Instructions.

Where a formal “Permits to Work” system is implemented in the plant it must be complied with.

### 1.4. Personal protective equipment

Personal protective equipment should always be worn during work in order to protect against hazards posed by e.g. the process medium, dangerous temperatures, noise, falling or projected objects, and working at height. This equipment includes a helmet, safety glasses, safety harness, protective clothes, safety shoes, hearing protection, etc.

#### NOTE

Always assess whether you or others in your vicinity require any protective equipment. When in doubt check with the plant’s health & safety responsible personnel for details on required protective equipment.

### 1.5. The system

The complete system should be assessed as well as every action (e.g. closing of shut-off valves, disconnection of the power supply) to ensure this will not bring additional risk to personnel or property.

Dangerous actions that can result in a hazardous situation include isolation of protective devices such as safety valves, vents, vacuum relief valves, disconnection of electric safety devices, sensors, and alarms.

## 1.6. ATEX

If the product is in the scope of the ATEX 2014/34/EU directive and as such bears the Ex marking, consult its specific Additional Instructions for use in Potentially Explosive Areas (IMI EX). In such cases, handling, installation, operation, and maintenance work must only be performed by personnel qualified and authorized to work in potentially explosive areas.

## 1.7. General safety notes



### DANGER

#### RISK OF BURSTING OR IMPLOSION IN PRESSURE EQUIPMENT

Valves, ancillaries, and pipelines are pressure equipment. Working outside their operating limits, improper opening, malfunction, or system operation failure may result in component bursting or implosion.

- Observe the maximum and minimum operating limits of the product and check if they are within those of the system in which it is being installed. If not, ensure a safety device is included in the system to prevent operation outside those limits. Check the product Information Sheet (IS).
- In case the malfunction of any equipment installed on the system or a system operation failure may result in a dangerous overpressure, overtemperature, or vacuum condition, ensure a safety device is included in the system to prevent such situation.
- Before starting any work on the product, depressurize it and cool or heat it to ambient temperature. This also applies to the line in which it is fitted.
- Drain the process medium from the product and all the relevant plant sections.



### WARNING

#### RISK OF BURNS

Depending on the operating conditions, products, and pipelines may get very hot or cold and cause burn injuries.

- Do not touch the product while it is hot or cold, allowing it firstly to cool down or heat up.
- Wear protective clothing and safety gloves during working operations.
- Thermally insulate tubes and products as a preventive measure.



## WARNING

### **RISK OF INJURY CAUSED BY FLUID ATTACK ON PRODUCTS MATERIALS**

The product must only be used with mediums that do not attack the materials of the product (body, gaskets, seals). Otherwise, leaks may occur, and hot and/or hazardous fluid can escape.

- Do not use the product with mediums other than the ones it was designed for. Check section 1.2 - Intended Use.
- Prevent medium contamination.

### **RISK OF INJURY CAUSED BY UNDER TIGHTENED PRODUCT OR ITS COMPONENTS**

Excessively low tightening torques may cause medium to escape and/or components to be projected at high speed which may result in a hazardous situation depending on the medium, chemical properties, and/or its operating conditions.

- Do not loosen any screws while the equipment is pressurized.
- Observe the specified tightening torques on these Installation and Maintenance Instructions. If the relevant torque value is not mentioned contact VALSTEAM ADCA.

### **RISK OF HEARING LOSS**

Depending on the operating conditions, the product may generate loud noises.

- Wear hearing protection when in the vicinity of the product.

### **RISK OF INJURY AS A RESULT OF ILLEGIBLE INFORMATION**

Important information written in the product nameplate, markings, and warning signs may wear over time or become illegible due to e.g. dirt accumulation, resulting in hazardous situations and personal injury or property damage.

- Keep nameplates, markings, and warning signs in a legible state, replacing them when illegible, missing, or damaged.



## CAUTION

### **RISK OF INJURY DUE TO RESIDUAL PROCESS MEDIUM**

Direct contact with a dangerous process medium may lead to personal injury, e.g. smoke inhalation and chemical burns.

- Drain the process medium from the product and all the relevant plant sections.
- Wear protective clothing, safety gloves, mask, and eye protection.



## CAUTION

### RISK OF INJURY DUE TO IMPROPER HANDLING

Manual handling (e.g. lifting, carrying, pushing, pulling) of large and/or heavy products may result in personal injury.

- Assess the risk associated with the handling task.
- Use adequate handling methods and appropriate auxiliary handling equipment.



## NOTICE

### RISK OF PRODUCT DAMAGE DUE TO EXCESSIVELY HIGH TIGHTENING TORQUES

High tightening torques may lead to premature wearing of product components.

- Observe the specified tightening torques on these Installation and Maintenance Instructions. If the relevant torque value is not mentioned contact VALSTEAM ADCA.

## 2. PRODUCT INFORMATION

The ADCAPure P161 is a series of inline direct acting, diaphragm sensing pressure reducing valves. These regulators, available with spring or dome-loading, are designed for use with clean steam, compressed air, water, and other gases or liquids compatible with the construction materials and valve design. The regulators are supplied with clamped (TC) or extended tube weld (ETO) connections and are available with various configurations and options.

### 2.1. Principle of operation

The function of a pressure reducing valve is to reduce medium pressure from a higher upstream pressure to a lower downstream pressure, keeping it as stable as possible while other conditions such as flow demand vary.

During start-up, the valve is kept closed due to the force exerted by the upstream pressure ( $P_1$ ) below the plug assembly (4, 5, 6) and the force of the return spring (12B).

Spring-loaded versions (standard): Clockwise rotation of the adjustment knob (19) compresses the adjustment spring (16) and increases the loading force  $F_L$ .

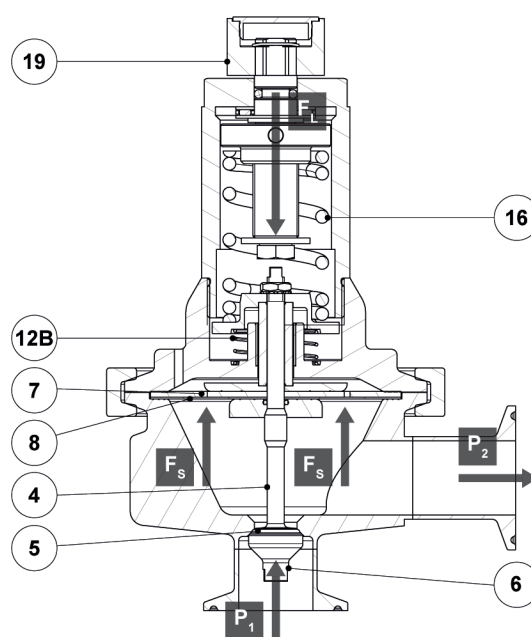

Fig. 1



Dome-loaded versions (variant “A”): The loading force  $F_L$  is established by a gas pressure fed into the dome chamber. Gas is supplied by a pilot regulator or an I/P converter.

When the loading force  $F_L$  is applied, the diaphragms (7, 8) deflect and the stem (4) moves downwards, opening the valve and admitting process medium to the downstream pipework, increasing downstream pressure. The downstream pressure acts below the diaphragms (7, 8), applying a force  $F_S$  that counteracts the loading force  $F_L$  and eventually closes the valve when the set pressure is reached. When system consumption increases, downstream pressure drops and so does the force it applies on the bottom side of the diaphragms. As a result, the valve opens to try to reach the initial set pressure as long as the downstream system is demanding flow.



**NOTE**

A pressure reducing valve is not a shut-off device and as such there is almost always a small amount of leakage between seat and plug. For this reason, a shut-off valve should be used downstream of the regulator when isolation is required.

## 2.2. Certification

This product has been specifically designed for use with liquids and gases which are in Group 2 of the European PED – 2014/68/EU Pressure Equipment Directive and it complies with its requirements.

CE MARKING – GROUP 2 (PED – European Directive)	
PN10	Category
1/2" to 2" – DN 15 to 50	SEP



**NOTE**

If the product falls within category SEP it must not be CE marked, unless other directives are applicable.

This product is not in the scope of the ATEX 2014/34/EU directive as it does not have its potential ignition source. Personnel responsible for the plant installation must assess the risks caused by static electricity and take the necessary precautionary measures to prevent static charge. These measures include e.g. connection of the product to the equipotential bonding system.

The product has been designed in accordance with ASME BPE and EHEDG guidelines.

The product surface finishing conditions and non-metallic material approvals such as FDA and USP CL. VI are detailed in the ADCAPure specific inspection certificate.

Refer to IS PV20.00 Technical Information Sheet - ADCAPure for further information.

## 2.3. Product identification

The following items are indicated on the product nameplate or directly on its body:

- Manufacturer
- Product model (e.g. P161)
- Pressure rating (e.g. PN10) or maximum allowable pressure (e.g. Pmax = 10 bar)
- Nominal size (e.g. TC 1/2" BPE)
- Min. operating temperature (e.g. Tmin = -10°C)
- Max. operating temperature (e.g. Tmax = 150°C)
- Flow direction (indicated by an arrow)
- Serial number and year of manufacturing (e.g. Reg.:17483/19)
- CE Marking (when applicable – see section 2.2 – Certification)
- EX Marking (when applicable e.g. EX h IIB T6...T3 Gb – see section 2.2 – Certification)

## 2.4. Technical data

For technical data including dimensions, materials, limiting conditions and versions refer to the product's respective Information Sheet (IS).

## 2.5. Factory assembly and cleaning

Assembly of the product is performed in a certified clean room according to ISO 14644-1 and all its components are cleaned and, when admissible, degreased and passivated. Such operations are performed in accordance with certified procedures and rigorous control.

### 3. TRANSPORT, STORAGE, AND PACKAGING



#### WARNING

##### **RISK DUE TO FALLING LOADS**

Loads may tip or fall over resulting in damage to property, serious injury, or death.

- Use suitable equipment when moving or lifting suspended loads.
- Make sure no one is standing below the suspended load.



#### CAUTION

##### **RISK OF INJURY DUE TO IMPROPER HANDLING**

Manual handling (e.g. lifting, carrying, pushing, pulling) of large and/or heavy products may result in personal injury such as back injury.

- Assess the risk associated with the handling task.
- Use adequate handling methods and appropriate auxiliary handling equipment.



#### NOTICE

##### **RISK OF PRODUCT DAMAGE DUE TO IMPROPER STORAGE**

- Do not remove any packaging or protective covers until immediately before installation at the site.
- Store the product in a solid base in a dry, cool, and dust-free environment.
- Until its installation, protect it from the weather, dirt, corrosive atmospheres, and other harmful influences.

##### **RISK OF PRODUCT DAMAGE DUE TO LONG-TERM STORAGE**

Some product components may deteriorate with time (e.g. valve packings, seals).

- Do not store the product for more than 12 months.
- If for any reason the product must be stored for longer periods contact VALSTEAM ADCA.

The product is end-capped and sealed with recyclable thermo shrinkable plastic film inside the clean room where it was assembled to prevent contamination as it leaves the clean environment. The product is stored in a cardboard box as it leaves VALSTEAM ADCA. Avoid removing packaging, covers, and sealings until immediately before installing the product at the site.



#### NOTE

If the transport packaging has any shipping damage contact VALSTEAM ADCA or its representative.

Before storing and transporting the product protect it from impacts and mechanical damage, paying special care to sealing surfaces and other fragile parts.

## 4. INSTALLATION

Before performing any installation work, refer to section 1 – Safety information.



#### WARNING

##### **RISK OF INJURY DUE TO INSUFFICIENT SUPPORT DURING INSTALLATION**

Insufficient support of the product during installation may cause it to fall and cause personal injury.

- Ensure the product is safely held in place during installation.
- Wear protective safety shoes.



#### CAUTION

##### **RISK OF INJURY AND PRODUCT MALFUNCTION DUE TO PRESSURIZED SPRING CHAMBER**

Plugging or isolating the leakage line connection in a self-relieving regulator will result in pressurization of the spring chamber, altering the regulator set pressure and causing medium to escape and/or components to be projected at high speed during disassembly.

- The leakage line connection must be kept depressurized.



#### NOTICE

##### **RISK OF PRODUCT DAMAGE DUE TO STRESS**

The product is not intended to withstand external stresses that may be inducted by the system to which it is being connected.

- Make sure that the connected pipe does not subject the body to any stress (forces or torques) during installation and operation.
- Do not use the product as an elevation point.

## 4.1. Preparation for installation

Before installation, make sure the following conditions are met:

- The installation area has easy access and the product is to be installed in a position where operation and maintenance work can be performed safely.
- The product will be installed with proper support and free of any stresses that can be induced by the system due to e.g. thermal pipe expansions/contractions during CIP/SIP. The necessary precautions are recommended during system design.
- The pipeline where the product will be installed is designed in such a way that it takes into account the weight of the product. The pipeline may require support on both sides next to the product, particularly if its size and weight are considerable and especially if vibrations are to be expected in the system.
- Consider good hydraulic flow control to avoid pressure surges and dead legs on pipeline branches.
- The product is not damaged.
- Make sure all the necessary materials and tools are readily available during installation work.
- Referring to this Installation and Maintenance Instructions (IMI), Information Sheet (IS), and nameplate, check that the product is suitable for the intended installation: temperature, medium, pressure, etc. – see section 1.2 – Intended use.
- Check that there are no foreign bodies inside the pipelines and ancillaries, flushing may be necessary. These should be thoroughly cleaned.
- A filter may be necessary to install upstream of the regulator in some applications, protecting it from solid particles.
- A safety valve must be installed downstream if the inlet pressure to the regulator can exceed its maximum downstream pressure rating or the pressure rating of any equipment installed downstream.
- A shut-off valve is installed upstream and downstream of the regulator to facilitate start-up, maintenance, and troubleshooting. A bypass line is recommended as it additionally prevents system shutdown during maintenance procedures, in which case a manual valve should be fitted to allow regulation of downstream pressure.
- The pressure regulator will not be thermally insulated.
- A pressure gauge is installed both upstream and downstream of the regulator for monitoring, set point adjustment, and troubleshooting.



### NOTE

If the regulator is fitted with an integrated downstream pressure gauge, the displayed pressure may be slightly higher compared to a separate gauge installed further downstream.

- In steam and other vapour applications, the medium should be dry and free of impurities. In case of steam applications in particular, a humidity separator with an appropriate trapping set trap is strongly recommended.
- Additionally, for dome-loaded variants make sure:
  - The gas supply is dry and free of oil.
  - If a pilot regulator is used, then it should be of self-relieving type and its maximum outlet pressure to the dome chamber may not exceed the downstream pressure rating of the regulator.



#### NOTE

Assembly Drawings (AD) with assembly details and parts lists are available on request.

## 4.2. Installation procedure

1. Remove plastic film and other packaging, as well as the protective covers that are placed on flanges or connection ends. Make sure the regulator is free from foreign matter.
2. Handle the regulator carefully to prevent damage to its surface finish.
3. The regulator recommended installation position is horizontal with the adjustment knob pointing upwards. Other installation positions may increase wear and shorten the valve's service lifetime.
4. The regulator has an arrow or inlet/outlet designation, be sure that it is installed in the appropriate direction according to fluid flow.
5. When a clamp ferrule version is being installed, use appropriate gaskets. Sanitary clamps must respect the system operating limit conditions.
6. When an ETO version is being installed, the welding should be carried out by qualified personnel following an appropriate orbital welding procedure.
7. For dome-loaded regulators, connect the control pressure line to the dome chamber threaded port using suitable fittings and tubing.

## 5. START-UP

Before performing the start-up procedure, refer to section 1 – Safety Information.

The start-up procedure must be followed every time the product is put back into service.

### 5.1. Preparation for start-up

Before starting up, make sure the following conditions are met:

- All works on the system have been completed.
- All the necessary safety devices have been installed.
- When required, warning notices are used to alert others that the system is starting up.
- The product is correctly installed – see section 4 – Installation.
- Referring to these Installation and Maintenance Instructions (IMI), Information Sheet (IS), and nameplate, check that the product is suitable for the intended installation: temperature, medium, pressure, temperature, etc. – see section 1.2 – Intended use.
- A safety check was performed by qualified personnel. Checking for leaks, structural damage and integrity of system components.
- For spring-loaded regulators, the adjustment spring is completely relaxed. If not, release tension by turning the adjustment knob (26) counterclockwise.
- For dome-loaded regulators, the dome chamber is depressurized.



#### NOTICE

##### **RISK OF PRODUCT DAMAGE DUE TO CONTAMINATION**

The plant operator is responsible for cleaning the pipelines in the plant as well as keeping the product well-maintained. At start-up, the presence of small particles in the medium (dirt, scale, weld splatters, etc.) may damage the product or cause malfunction.

- Flush pipelines before start-up.
- Clean protection varnishes from pipes and flanges, leftover paint, graphite, grease, etc.
- Use a pipeline strainer or a filter.

### 5.2. Start-up procedure

1. Partially open the downstream shut-off valve.
2. Slowly open the upstream shut-off valve to prevent sudden surges of pressure that can damage the regulator.

3. For spring-loaded regulators: Operation is performed by turning the adjustment knob (19) clockwise to increase downstream pressure and counterclockwise to decrease downstream pressure. Turn the adjustment knob clockwise until the flow is allowed through the regulator, monitoring with the aid of the downstream pressure gauge.
4. For dome-loaded regulators: Operation is performed by increasing loading control pressure to increase downstream pressure and decreasing loading control pressure to decrease downstream pressure. Increase loading control pressure until the flow is allowed through the regulator, monitoring with the aid of the downstream pressure gauge.
5. Continue to slowly open the downstream shut-off valve, especially while the downstream system is not pressurized. This will allow pressure to build up slowly.
6. Operate the regulator until the desired set pressure is achieved. In spring-loaded regulators, make sure the final adjustment is made in the direction of increasing pressure (clockwise rotation of the adjustment knob) to obtain the most accurate set pressure.



#### NOTE

In dome-loaded regulators, depending on the model, the loading control pressure can be up to a maximum of 1,2 bar above the required downstream pressure.

7. Check for any leaks.
8. Check the pressure regulator to ensure it is operating correctly.

## 6. OPERATION

**Before operating the product refer to section 1 – Safety Information.**

Immediately after completing the start-up procedure, the product is ready for operation.



#### WARNING

##### **RISK OF INJURY DUE TO VENTING IN SPRING LOADED REGULATORS**

Spring loaded regulators with self-relieving option and without leakage line connection will vent the medium to the atmosphere through the cover.

- When working with hazardous fluids in regulators with self-relieving option make sure it is also fitted with leakage line connection directed to a safe place.



## 6.1. Using the CIP/SIP locking system

The ADCAPure P161 is available with an optional pin (60) that allows the valve to be locked in the open position in order to perform e.g. a clean-in-place procedure. The locking pin (60) is attached to the cover (2) by using a chain.

To lock the valve open with the pin (60) ensure firstly that the system is not pressurized and the valve is open. Then insert the pin in the hole of the intermediate cover (3) thus preventing the valve from closing and allowing flow and drainage of the cleaning media.



### NOTE

Remove the locking pin before placing the valve back into operation.

## 7. SHUTDOWN

Before performing the shutdown procedure, refer to section 1 – Safety Information.

### 7.1. Shutdown procedure

1. Switch off the system and secure it so it cannot be turned on by unauthorized personnel.
2. Fully close the upstream shut-off valve, to stop the process medium from flowing through the pressure regulator.
3. Allow medium to cool down and completely drain it from the pipeline and pressure regulator.
4. Make sure the pipeline and pressure regulator are not under pressure and are at a safe temperature.
5. Fully close the downstream shut-off valve.
6. If the pressure regulator won't be put back in operation for a long period relax the regulating spring or disconnect the loading control pressure supply.
7. If the pressure regulator is to be removed from the pipeline – see section 3 - Transport, storage, and packaging.

## 8. PARTS LIST

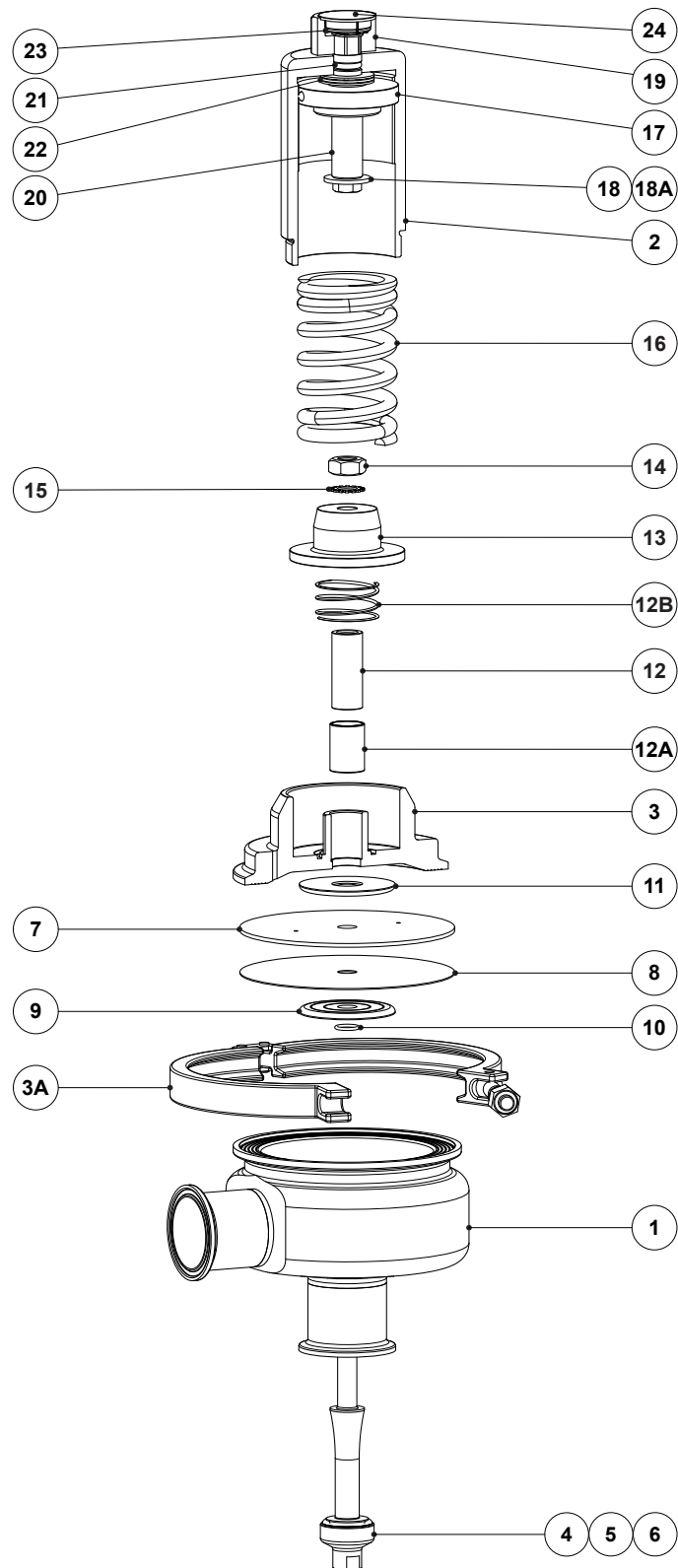

Fig. 2

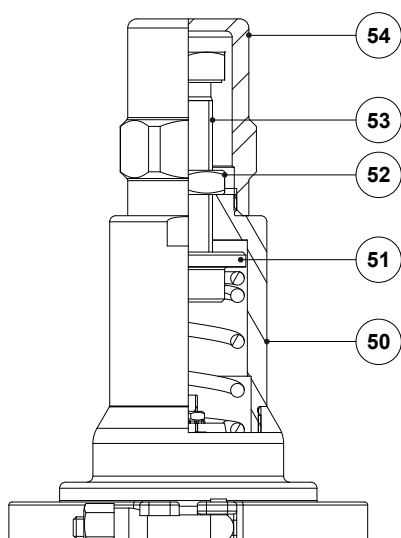

Fig. 3 - Optional top cap

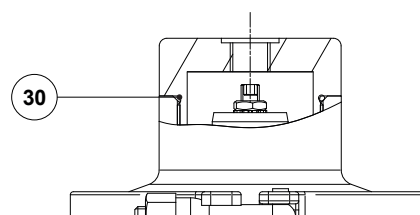

Fig. 4 - Optional dome-loading

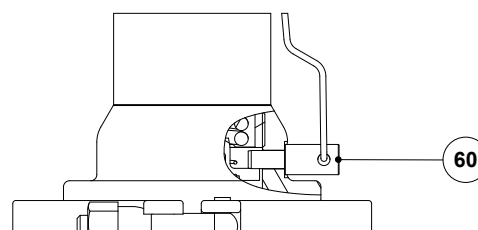

Fig. 5 - Optional lock system

POS. N°	DESIGNATION	SPARE PARTS
1	Valve body	
2	Cover	
3	Intermediate flange	
3A	Clamp	
4	Valve stem	X
5	Valve seal	X
6	Valve plug	X
7	Upper diaphragm	X
8	Lower diaphragm	X
9	Lower diaphragm plate	
10	O-ring	X
11	Upper diaphragm plate	
12	Stem guide	
12A	Plain bearing	
12B	Spring	
13	Spring plate	
14	Nut	
15	Washer	X

POS. N°	DESIGNATION	SPARE PARTS
16	Adjustment spring	X
17	Top spring plate	
18	Washer	
18A	Bolt	
19	Adjustment knob	
20	Adjustment screw	
21	O-ring	
22	Bearing	
23	Shaft ring	
24	Cover nut	
30	O-ring	X
50	Cover	
51	Spring guide	
52	Lock nut	
53	Adjustment screw	
54	Top cap	
60	Locking pin	

## 9. MAINTENANCE

Before performing a maintenance procedure, refer to section 1 – Safety information.

The product requires maintenance to ensure that it operates correctly and safely throughout its lifetime. Maintenance work should be performed in a planned manner at periodic intervals. These intervals must be defined by the operator according to the service conditions.

### 9.1. Maintenance procedure

1. Make sure all the necessary materials and tools are readily available during maintenance work.
2. Perform the shutdown procedure – see section 7 – Shutdown.
3. Perform the maintenance procedure – see the following sections.
4. Put the product back into operation – see section 5 – Start-up.

### 9.2. Replacing plug assembly and diaphragms

1. Completely relax the adjustment spring (21) or disconnect the loading control pressure supply. If the valve is removed from the line, fix the valve body (1) in a vise with soft jaws, with the cover (3) pointing upwards.
2. Unscrew the cover (2), remove the O-ring (30) if the regulator is dome-loading, and adjust spring (16) if spring-loaded.
3. Fix the valve stem (4) with a suitable wrench, unscrew the nut (14), and discard the washer (15).
4. Remove the spring plate (13), spring (12B) and stem guide (12).
5. Remove the intermediate cover safety clamp (3A) and separate the body (1), intermediate cover (3), diaphragms (7, 8), plates (9, 11), O-ring (10), and plug assembly (4, 5, 6).
6. Thoroughly inspect and clean all surfaces and all parts that will not be discarded, with special attention to the seat surface on the valve body (1) and valve seal (5) stem guide (12), and plain bearing (12A).



#### NOTE

After thoroughly cleaning the valve body interior, if the seating surface is not in good condition contact VALSTEAM ADCA.

7. Insert a new plug assembly (4, 5, 6) through the bottom of the valve body with care not to damage the seating surface. Place the lower diaphragm plate (9) with a new O-ring (10) through the top of the stem (4) and push until reaching a mechanical stop.

8. Fit the diaphragms (7, 8) and upper diaphragm plate (11) followed by the intermediate flange (3), closing with safety clamp (3A) and tightening with the recommended torque – see section 9.3 - Tightening torques.
9. Slide the stem guide (12), place the spring (12B) and the spring plate (13).
10. Insert a new washer (15), screw the nut (14), fix the valve stem (4) with a suitable wrench, and tighten the nut with the recommended torque – see section 9.3 - Tightening torques. Perform this procedure while pushing the spring plate (13) downwards to prevent the valve seal from touching the seating surface.
11. Place the adjustment spring (16) over the spring plate (13) if the regulator is spring-loaded. Place a new O-ring (30) if the regulator is dome-loaded.
12. Screw the cover (2) onto the intermediate cover (3) and tighten with the recommended torque – see section 9.3 - Tightening torques.

### 9.3. Tightening torques

POS. N°	DESIGNATION	TORQUE (Nm)	
		1/2" to 1" – DN 15 to 25	1 1/2" and 2" – DN 40 and 50
2	Cover	35	50
3A	Safety clamp	4-5	4-5
14	Nut	15	35

## 10. TROUBLESHOOTING

Before applying any corrective measure, refer to section 1 – Safety information.

If the malfunction cannot be solved with the help of the following table, contact VALSTEAM ADCA or its representative.

Malfunction	Possible cause	Corrective measure
<b>Downstream pressure rises above the adjusted set pressure.</b>	Seat and/or plug is worn or damaged.	<ul style="list-style-type: none"> <li>Replace plug assembly – see section 9.2. If the valve is equipped with a metal plug, consider replacing it with a soft plug option for tighter shut-off.</li> <li>Analyze the root cause of damage. In case of steam application, verify need to install a humidity separator with suitable trapping set.</li> <li>If the valve seating surface is damaged contact VALSTEAM ADCA.</li> </ul>
	Foreign matter is stuck between seat and plug.	<ul style="list-style-type: none"> <li>Remove foreign matter and replace the seat if necessary – see section 9.2.</li> <li>If the valve seating surface is damaged contact VALSTEAM ADCA.</li> <li>Consider installing a filter upstream of the regulator.</li> </ul>
	Bypass valve is leaking.	<ul style="list-style-type: none"> <li>Check, clean, and replace the bypass valve if necessary.</li> </ul>
<b>Downstream pressure does not reach the required set pressure.</b>	The adjustment spring regulating range is incorrect.	<ul style="list-style-type: none"> <li>Replace the adjustment spring.</li> </ul>
	The inlet upstream pressure to the regulator is too low or there is insufficient flow rate to meet the system consumption.	<ul style="list-style-type: none"> <li>Ensure that the upstream pressure to the regulator is equal to or greater than the required set pressure at minimum and maximum consumption scenarios.</li> </ul>
	Foreign matter is blocking the valve or flow restriction is limiting flow through the valve.	<ul style="list-style-type: none"> <li>Remove foreign matter and consider installing a filter upstream of the regulator.</li> <li>Check and solve flow restrictions (e.g. fully opening a partially open shut-off valve, cleaning clogged filter elements, etc.).</li> </ul>
	The regulator is undersized.	<ul style="list-style-type: none"> <li>Check valve sizing and if necessary, install a different sized regulator.</li> <li>Contact VALSTEAM ADCA.</li> </ul>
<b>Leakage between body and cover or through the adjustment knob or screw.</b>	The lower diaphragm (8) is damaged.	<ul style="list-style-type: none"> <li>Replace damaged diaphragms – see section 9.2.</li> </ul>
	Safety clamp tightening torques are too low.	<ul style="list-style-type: none"> <li>Tighten safety clamps (3A) with the recommended torque – see sections 9.3 – Tightening torques.</li> </ul>
	Gasket (3B) is damaged.	<ul style="list-style-type: none"> <li>Replace gasket (3B). Tighten safety clamps (3A) with the recommended torque – see sections 9.3 – Tightening torques.</li> </ul>
<b>The regulator is hunting or chattering.</b>	The flow rate through the regulator is too low. The regulator is oversized.	<ul style="list-style-type: none"> <li>Check valve sizing and if necessary, install a smaller regulator.</li> <li>Contact VALSTEAM ADCA.</li> </ul>
	The reducing ratio is too high.	<ul style="list-style-type: none"> <li>Install a second regulator in series (two-stage reduction).</li> <li>Contact VALSTEAM ADCA.</li> </ul>
<b>The downstream pressure rises too much when flow rate is reduced to a static condition (no consumption).</b>	Flow rate through the regulator is too high.	<ul style="list-style-type: none"> <li>When occurring during start-up, allow downstream system to pressurize slowly to prevent damage to the regulator.</li> <li>Check valve sizing and if necessary, install a larger regulator or a second regulator in parallel.</li> <li>Contact VALSTEAM ADCA.</li> </ul>

## 11. DISPOSAL

Once the product has reached the end of its working life, it should be sent for disposal in accordance with the prevailing national and local regulations.

Before disposal make sure that the product is clean and free from fluid residues.

During its disposal, pay special attention to rubbers, resins and polymer components (PVC, PTFE, PP, PVDF, FKM, NBR, etc.).

Do not dispose of components and hazardous substances together with household waste.

## 12. RETURNING PRODUCTS

Information regarding hazards and precautionary measures to be considered due to contaminating fluids and residues or mechanical damage that may represent a health, safety or environmental risk, must be provided in writing when returning products to VALSTEAM ADCA.



### WARNING

#### **RISK DUE TO PRESENCES OF HAZARDOUS RESIDUES ON RETURNED PRODUCTS**

Contaminated fluids and residues may represent an environmental risk, or risk to VALSTEAM ADCA personnel.

- Information regarding any hazards or precautionary measures to be considered must be provided in writing when returning products to VALSTEAM ADCA.
- Health and Safety information sheets relating to any substances identified as hazardous or potentially hazardous must be provided outside the packaging.
- Use Hazmat labels on the packaging.

### IMPORTANT NOTE

Total or partial disregard of these Installation and Maintenance Instructions involves loss of any right to warranty.

The extent and warranty period are specified in the “General sales conditions”.