

FLOAT AND THERMOSTATIC STEAM TRAPS FLT29TW (SG iron ; 3" and 4" – DN 80 and DN 100)

DESCRIPTION

The FLT29TW is a range of high capacity float and thermostatic steam traps with integral air vent designed for modulating discharge of condensate, ensuring maximum system heat transfer.

Typical applications include unit heaters, heat exchangers, dryers, jacketed vessels and other applications where continuous discharge is essential and high flow capacities are involved.

MAIN FEATURES

Modulating discharge of condensate at steam temperature.
Unaffected by sudden or wide load and pressure variations.
No backing-up with condensate.

Excellent air discharge through its integrated air vent.

Flow direction can be easily changed by repositioning the body in relation to the mechanism and cover.

OPTIONS: Equalizing (vent) and drain connections.
HVV – Hand vent valve.
BDV – Blowdown valve.
AFZ – Anti-freeze device.
VB21M – Vacuum breaker.

USE: Saturated and superheated steam.

AVAILABLE MODELS: FLT29TW-4,5 , 10 and 14 – SG iron.

SIZES: 3" to 4"; DN 80 to DN 100.

CONNECTIONS: Flanged EN 1092-1 PN 16.
Flanged ASME B16.5 Class 150.

INSTALLATION: Horizontal or vertical installation.

MAX. ΔP: FLT29TW-4,5 – 4,5 bar
FLT29TW-10 – 10 bar
FLT29TW-14 – 14 bar

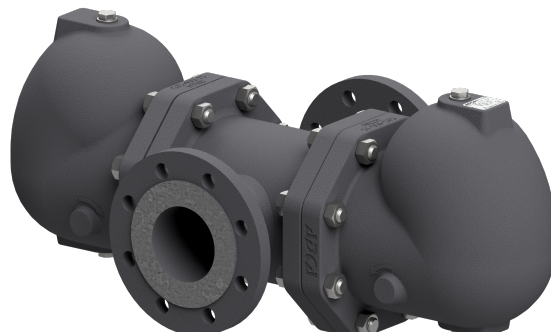

CE MARKING – GROUP 2 (PED – European Directive)	
PN 16	Category
3" to 4" DN 80 to 100	1 (CE marked)

BODY LIMITING CONDITIONS		
FLANGED PN 16 *	FLANGED CLASS 150 **	RELATED TEMP.
ALLOWABLE PRESSURE	ALLOWABLE PRESSURE	
16 bar	16 bar	100 °C
15,5 bar	14,8 bar	150 °C
14,7 bar	13,9 bar	200 °C
13,9 bar	12,1 bar	250 °C

PMO – Maximum operating pressure: 14 bar;

TMO – Maximum operating temperature: 198 °C.

* Acc. to EN 1092-2:2018; ** Acc. to ASME B16.42.

Body limiting conditions PN 16 or below, depending on the type of connection adopted.

FLOW RATE CAPACITY (kg/h)										
MODEL	SIZE	DIFFERENTIAL PRESSURE (bar)								
		0,5	1	1,5	2	4,5	7	10	12	14
FLT29TW-4,5	3" to 4" – DN 80 to 100	15100	22000	28000	31000	45000	–	–	–	–
FLT29TW-10	3" to 4" – DN 80 to 100	7800	10000	12200	14200	20000	27500	32000	–	–
FLT29TW-14	3" to 4" – DN 80 to 100	3800	5400	6200	7200	10000	13800	16200	18000	19600

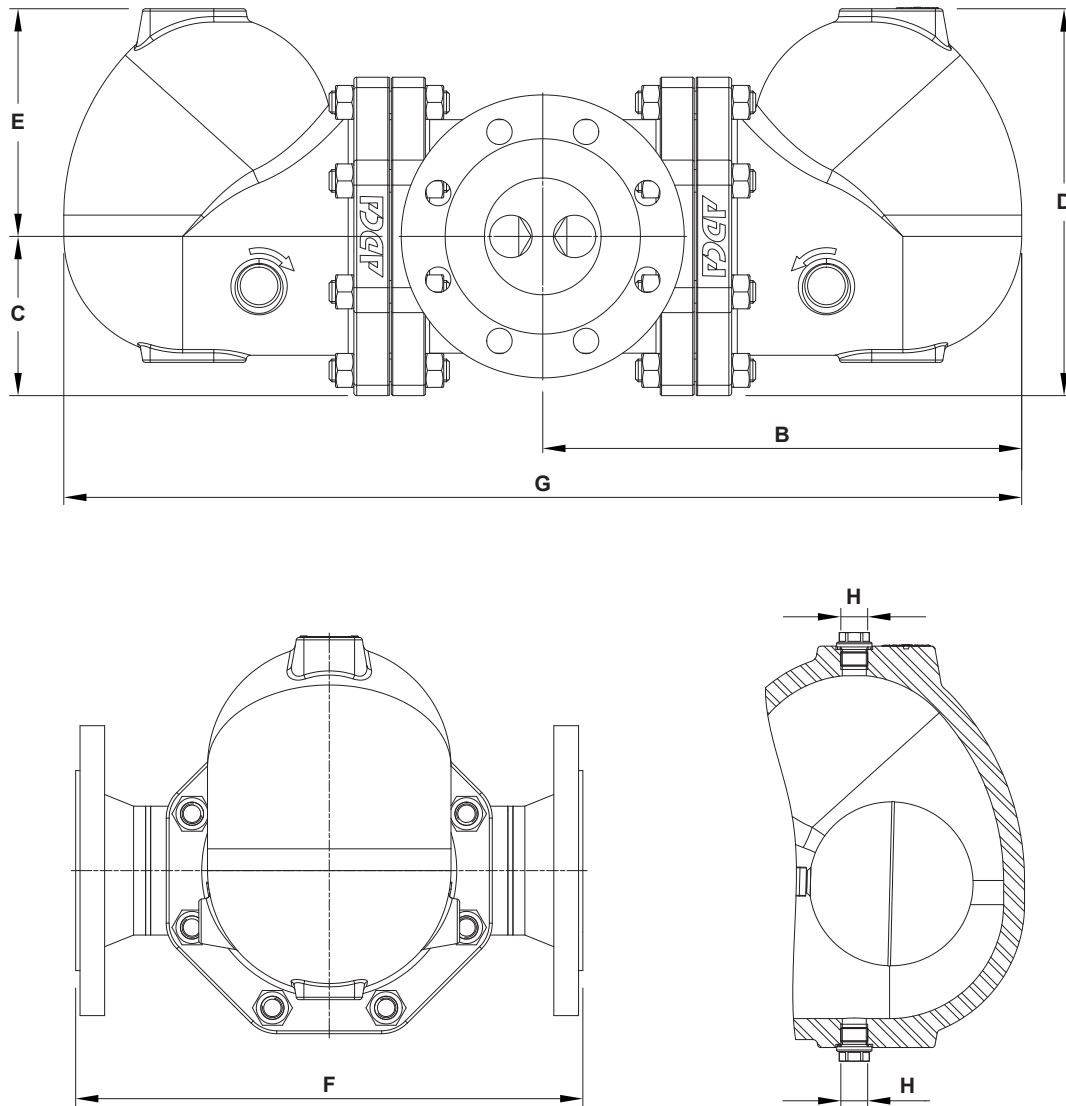

DIMENSIONS (mm)									
SIZE	PN 16							CLASS 150	
	B	C	D	E	F	G	H *	WEIGHT (kg)	WEIGHT (kg)
3" – DN 80	339	113	273	161	350	677	3/8"	86	86,6
4" – DN 100	339	113	273	161	350	677	3/8"	85,1	87,9

* As standard, in versions with EN flanges, these connections are female threaded ISO 228. In versions with ASME flanges, these connections are female threaded NPT.

MATERIALS

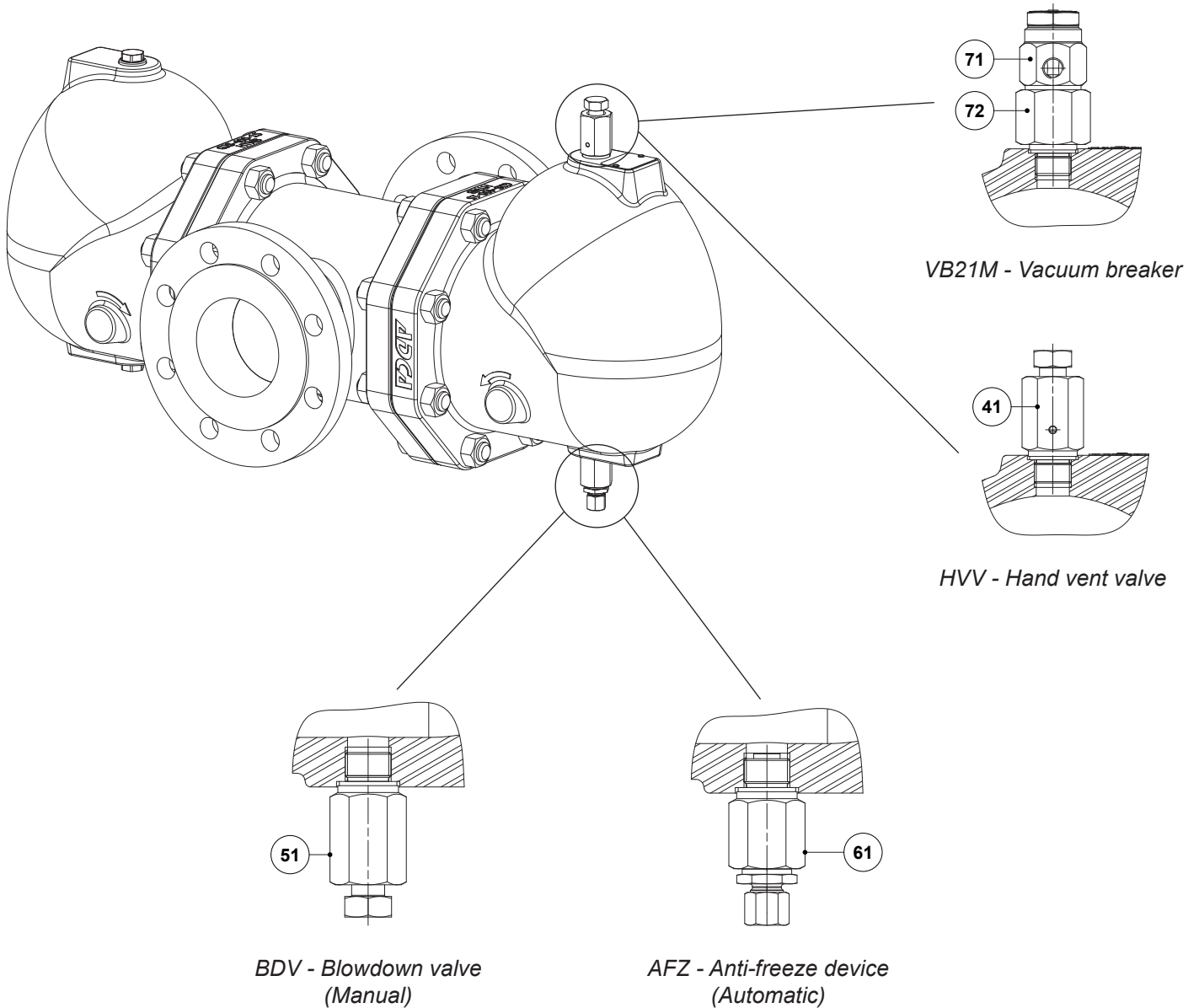
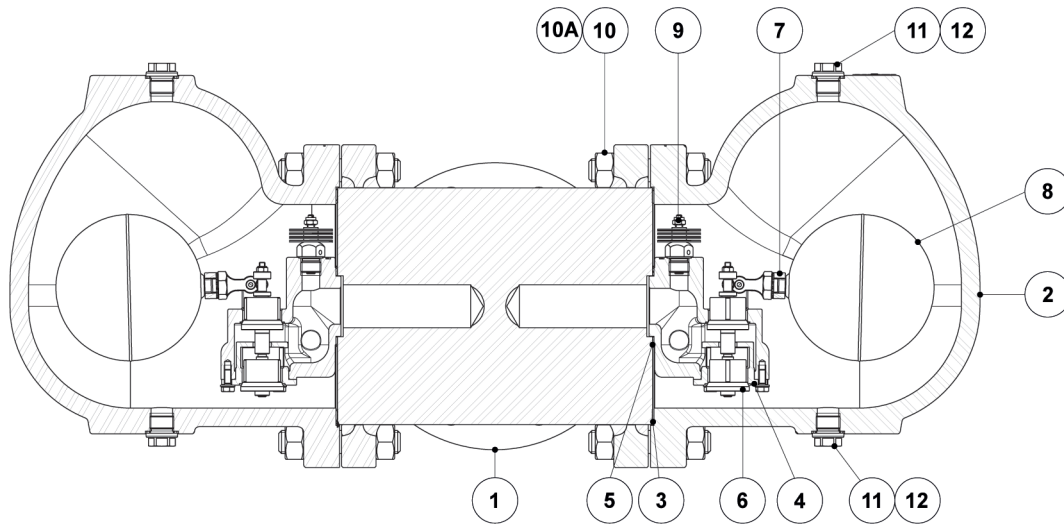

MATERIALS

POS. N°	DESIGNATION	MATERIAL
1	Body	P250GH / 1.0460; P235GH / 1.0345; S235JR / 1.0038
2	Cover	GJS-400-15 / 0.7040
3	* Gasket	Stainless steel / Graphite
4	* Seat	A351 CF8 / 1.4308; A276-98B / 1.4057
5	* Gasket	Stainless steel / Graphite
6	* Valve	AISI 316 / 1.4401; AISI 420 / 1.4021
7	* Lever	A351 CF8M / 1.4408
8	* Float	AISI 304 / 1.4301
9	* Automatic air vent	Stainless st. (bimetallic)
10	Studs	Zinc plated steel
10A	Nuts	Zinc plated steel
11	Plug	AISI 316L / 1.4404
12	** Gasket	Copper; AISI 304 / 1.4301
41	Hand vent valve	AISI 303 / 1.4305; AISI 316L / 1.4404
51	Blowdown valve	AISI 303 / 1.4305; AISI 316L / 1.4404
61	Anti-freeze device	AISI 303 / 1.4305; AISI 316L / 1.4404
71	Vacuum breaker	AISI 303 / 1.4305
72	Adapter fitting	AISI 303 / 1.4305

* Available spare parts; ** Not applicable in NPT version.

FLOW DIRECTION

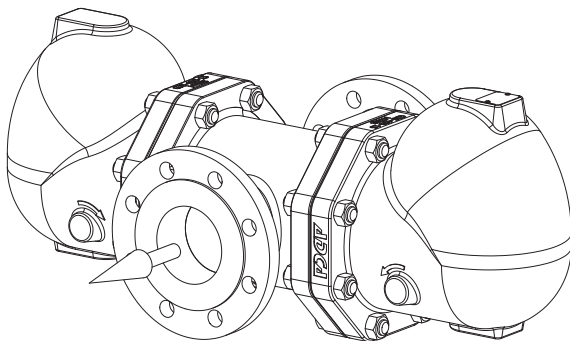

IH - Horizontal

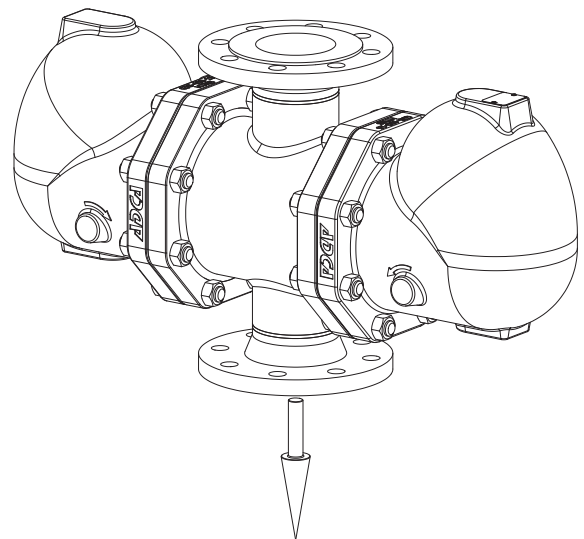

IT - Vertical from top to bottom



ORDERING CODES FLT29TW									
Model	A29T	2	V	XX	IH	L	80	E	
FLT29TW – GJS-400-15 / 0.7040 SG iron	A29T								
Differential pressure									
4,5 bar		2							
10 bar		3							
14 bar		4							
Automatic air vent									
Bimetallic air vent (standard)			V						
None			X						
Cover connections									
None				XX					
3/8" threaded connections on top and bottom, closed with plugs (mandatory if any options are considered)				10					
Options									
HVV, BDV, AFZ and VB21M have specific separated ordering codes, please refer to the appropriate documentation.									
Flow direction									
Horizontal						IH			
Vertical from top to bottom						IT			
Pipe connections									
Flanged EN 1092-1 PN 16							L		
Flanged ASME B16.5 Class 150							U		
Size									
3" or DN 80								80	
4" or DN 100								100	
Special valves / Extras									
Full description or additional codes have to be added in case of a non-standard combination									E