

AUTOMATIC AIR AND GAS VENTS FOR LIQUID SYSTEMS AE16SS

DESCRIPTION

The ADCA AE16SS all stainless steel air eliminator removes air from HVAC systems and are also suitable for non corrosive and/or dangerous liquids compatible with the construction, providing that their specific weight is no less than 0,75 kg/dm³.

This ball float type automatic air eliminator can be used in combination with other air elimination and separation systems or directly applied at high points in the piping.

MAIN FEATURES

Corrosion resistant working parts.

Replaceable internal parts.

OPTIONS: Integrated check valve.

USE: Cold and hot water systems.

AVAILABLE

MODELS: AE16SSE – EPDM valve.
AE16SSV – FPM valve.
Suffix "CK": With integrated check valve.

SIZES: 1/2" and 3/4".

CONNECTIONS: Female threaded ISO 7 Rp or NPT.
1/2" or 3/4" vertical inlet.
1/2" vertical outlet.

INSTALLATION: Vertical installation. It must be installed absolutely vertically at points in the plant where the air tends to collect. The drain should be piped to a safe position.
See IMI – Installation and maintenance instructions.



CE MARKING – GROUP 2 (PED – EUROPEAN DIRECTIVE)	
PN 16	CATEGORY
1/2" and 3/4"	SEP

BODY LIMITING CONDITIONS	
THREADED PN 16	RELATED TEMPERATURE
ALLOWABLE PRESSURE	
16 bar	100 °C
14,5 bar	150 °C
13,4 bar	200 °C
12,7 bar	250 °C

PMO – Maximum operating pressure: 14 bar.
TMO – Maximum operating temperature:
EPDM valve: 130 °C; FPM valve: 150 °C.
Minimum liquid specific weight: 0,75 kg/dm³.
Maximum working differential pressure: 12 bar.

FLOW RATE CAPACITY (NL/min)											
SIZE	DIFFERENTIAL PRESSURE (bar)										
	0,5	1	2	3	4	5	6	7	8	10	12
1/2" and 3/4"	47	70	109	145	182	218	255	291	327	400	473

Values shown refer to capacities of air discharge at 15 °C, under average atmospheric pressure (1013 mbar).

If the air temperature differs from 15 °C, the discharge capacity can be corrected by multiplying it by: $\frac{288}{273 + T}$, where T is the actual temperature in °C.
It may be assumed that the temperature of the air is equal to the temperature of the water.

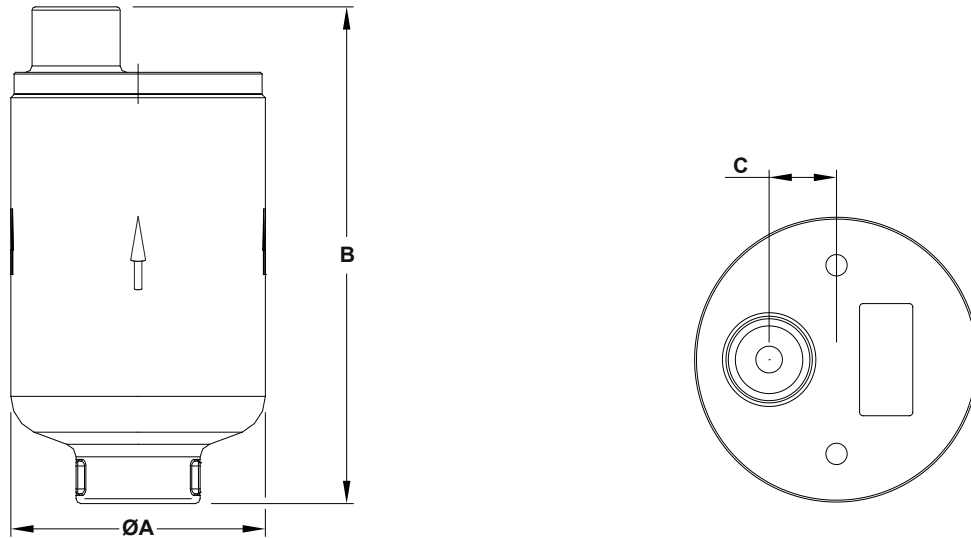

DIMENSIONS (mm)				
SIZE	ØA	B	C	WEIGHT (kg)
1/2"	78	152	19	1,5
3/4"	78	152	19	1,5

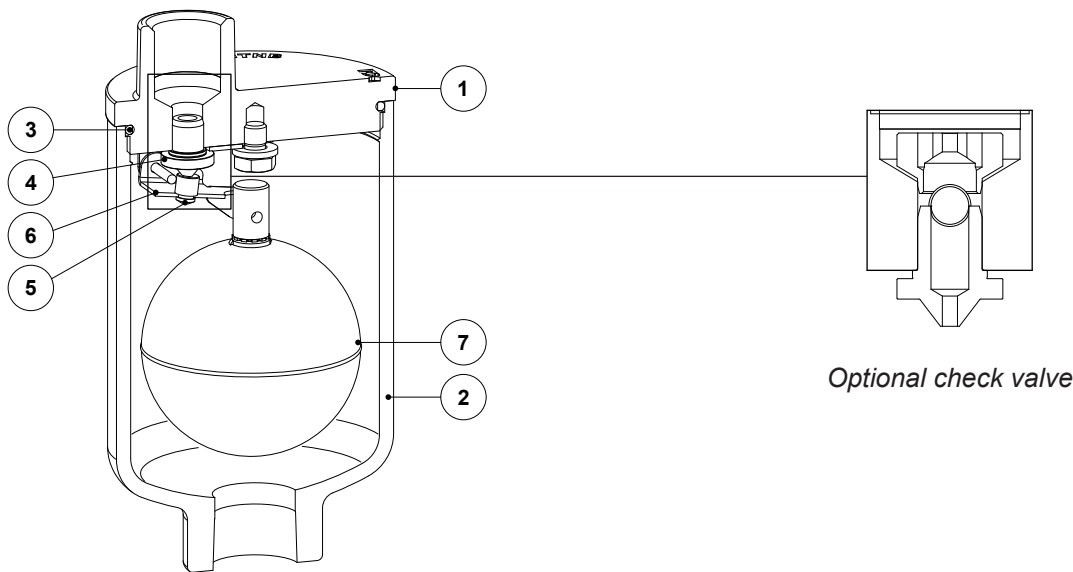

MATERIALS		
POS. No.	DESIGNATION	MATERIAL
1	Body	A351 CF8M / 1.4408
2	Cover	A351 CF8M / 1.4408
3	* O-ring	EPDM
4	* Seat	AISI 316 / 1.4401
5	* Valve	FPM; EPDM
6	* Lever mechanism	AISI 304 / 1.4301
7	* Float	AISI 304 / 1.4301

* Available spare parts.