

## SANITARY BALANCED PRESSURE THERMOSTATIC STEAM TRAPS TSS6

### DESCRIPTION

The ADCAPure TSS6 all stainless steel thermostatic steam traps and air vents are specifically designed for use in hygienic applications such as reactors, CIP/SIP, autoclaves, sterilizers and distribution lines in clean and pure steam systems.

Their small size makes them ideal for use with a wide variety of equipment.

### MAIN FEATURES

Modulating discharge.  
Excellent air discharge.  
Simple and compact design.

### STANDARD SURFACE FINISH

Internal wetted parts:  $\leq 0,51 \mu\text{m Ra} - \text{SF1}$ .  
External:  $\leq 0,76 \mu\text{m Ra} - \text{SF3}$ .  
Other surface conditions see TIS.GIA – General information ADCAPure.  
Ultrasonic cleaning.

OPTIONS: Special designs on request.

USE: Saturated clean steam.

AVAILABLE MODELS: TSS6 – clean steam trap.

SIZES: 1/2" to 1 1/2"; DN 08 to DN 25.

CONNECTIONS: ASME BPE, DIN and ISO clamp ferrules or tube weld (ETO) ends.  
Others on request.

PACKAGING: Assembling and packaging in a clean room certified according to ISO 14644-1.  
The product is end capped and sealed with recyclable thermo-shrinkable plastic film, to avoid contamination.

INSTALLATION: Vertical installation.  
See IMI – Installation and maintenance instructions.



#### CE MARKING – GROUP 2 (PED – EUROPEAN DIRECTIVE)

PN 10	CATEGORY
1/2" to 1 1/2" – DN 08 to 25	SEP

#### LIMITING CONDITIONS \*

Maximum allowable pressure	10 bar
Maximum allowable temperature	177 °C
Maximum operating pressure	6 bar
Maximum operating temperature	165 °C

\* Other limits on request. Maximum operating conditions may be limited by the steam trap end connections due to normative restrictions.

FLOW RATE CAPACITY (kg/h)										
MODEL	SIZE	DIFFERENTIAL PRESSURE (bar)								
		0,2	0,3	0,5	1	1,5	2	3	4	6
TSS6 (A)	1/2" to 1 1/2" – DN 08 to 25	320	380	410	550	680	909	1081	1199	1403
TSS6 (B)	1/2" to 1 1/2" – DN 08 to 25	470	495	518	697	792	1026	1231	1436	1682

A – Condensate discharge at 5 °C below saturation temperature; B – Cold water capacity around 20 °C.

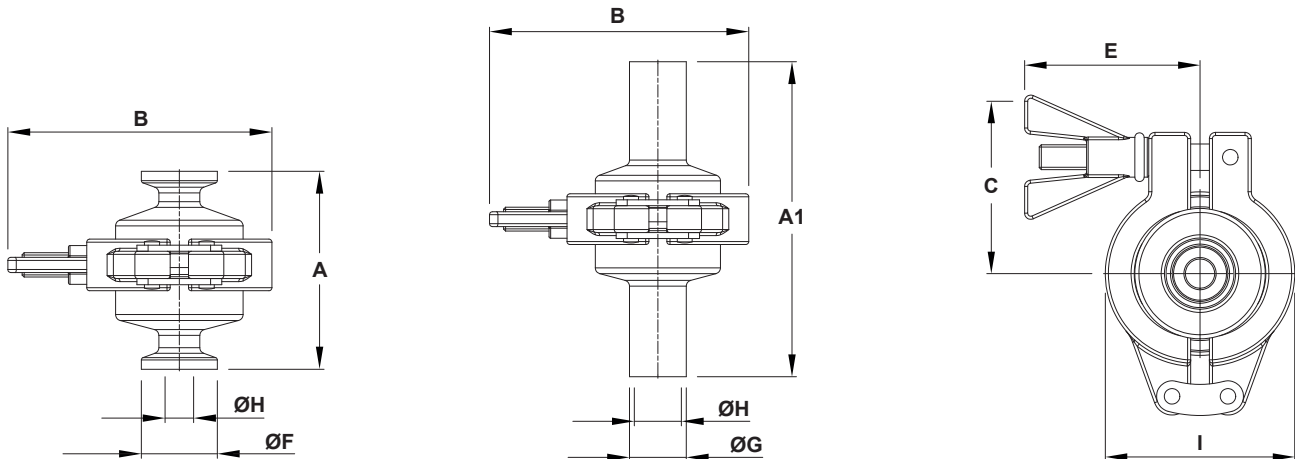

DIMENSIONS – ASME BPE (mm)										
SIZE	A	A1	B	C	E	ØF	ØG	ØH	I	WEIGHT (kg)
1/2"	65	95	87	57,5	56,5	25	12,7	9,4	61	0,7
3/4"	65	95	87	57,5	56,5	25	19,1	15,8	61	0,7
1"	65	95	87	57,5	56,5	50,4	25,4	22,1	61	0,8
1 1/2"	65	NA	87	57,5	56,5	50,4	NA	34,8	61	0,8

DIMENSIONS – DIN (mm)										
SIZE	A	A1	B	C	E	ØF	ØG	ØH	I	WEIGHT (kg)
DN 10	65	95	87	57,5	56,5	34	13	10	61	0,7
DN 15	65	95	87	57,5	56,5	34	19	16	61	0,7
DN 20	65	95	87	57,5	56,5	34	23	20	61	0,8
DN 25	65	95	87	57,5	56,5	50,5	29	26	61	0,8

Remarks: Clamp ferrules according to DIN 32676-A. Tube weld (ETO) according to DIN 11866-A (DIN 11850-2).

DIMENSIONS – ISO (mm)										
SIZE	A	A1	B	C	E	ØF	ØG	ØH	I	WEIGHT (kg)
DN 08	65	95	87	57,5	56,5	25	13,5	10,3	61	0,7
DN 10	65	95	87	57,5	56,5	25	17,2	14	61	0,7
DN 15	65	95	87	57,5	56,5	50,5	21,3	18,1	61	0,8
DN 20	65	95	87	57,5	56,5	50,5	26,9	23,7	61	0,8
DN 25	65	95	87	57,5	56,5	50,5	33,7	29,7	61	0,7

Remarks: Clamp ferrules according to DIN 32676-B. Tube weld (ETO) according to DIN 11866-B (ISO 1127).

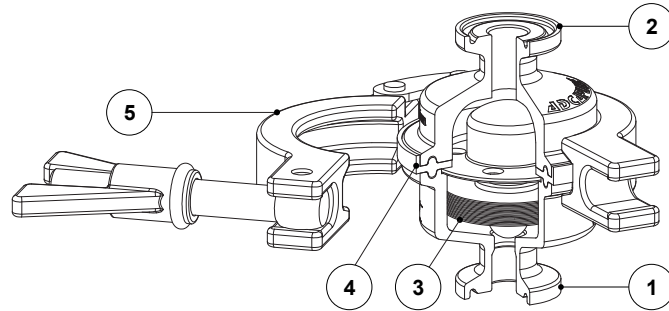

MATERIALS		
POS. No.	DESIGNATION	MATERIAL
1	Body	AISI 316L / 1.4404
2	Cover	AISI 316L / 1.4404
3	* Thermostat	AISI 316L / 1.4404
4	* Gasket	** Glass microsphere filled PTFE
5	Safety clamp	AISI 316 / 1.4401

\* Available spare parts. \*\* Others on request.  
Remark: FDA / USP Class VI seals certificate on request.

ORDERING CODES TSS6									
MODEL	TSS6	X	T	X	X	DX	08		
TSS6 – Sanitary thermostatic steam trap	TSS6								
<b>MATERIAL</b>									
AISI 316L / 1.4404		X							
<b>BODY SEALING</b>									
Glass microsphere filled PTFE			T						
<b>SURFACE FINISH (a)</b>									
Standard surface finish					X				
Mirror mechanical polished external surfaces (SF1)					P				
Electropolished internal wetted parts (SF5)					E				
Electropolished internal wetted parts (SF4)					Q				
<b>SPECIAL FEATURES</b>									
None						X			
<b>PIPE CONNECTIONS</b>									
Clamp ferrule ASME BPE							DX		
Clamp ferrule DIN (DIN 32676-A)							FX		
Clamp ferrule ISO (DIN 32676-B)							EX		
Tube weld (ETO) according to ASME BPE							DI		
Tube weld (ETO) according to DIN 11866-A (DIN 11850-2)							FI		
Tube weld (ETO) according to DIN 11866-B (ISO 1127)							EI		
<b>SIZE</b>									
DN 08									08
DN 10									10
1/2" or DN 15									15
3/4" or DN 20									20
1" or DN 25									25
1 1/2"									40
<b>SPECIAL CONSTRUCTION / ADDITIONAL OPTIONS</b>									
Full description or additional codes have to be added in case of non-standard combination									E

(a) Consult TIS.GIA – General information ADCAPure – for further details and other surface finish options.