

## SELF-ACTING TEMPERATURE REGULATORS TR40

### DESCRIPTION

The ADCATrol TR40 series of temperature regulators were designed for direct acting temperature control systems where the valve closes on temperature rise. They are single seated, unbalanced and intended to be coupled with T series thermostat models T.205 and T.405. The liquid filling the thermostat expands when the temperature of the fluid being heated rises, closing the valve.

These valves are used for controlling temperature in central and district heating systems, heat exchangers and other HVAC and industrial applications.

### MAIN FEATURES

- Easily adjustable temperature range.
- Proportional temperature control.
- Single seated, two way, direct acting valve.
- Built-in strainer.
- Narrow thermostat neutral zone (1,5 to 2,5 °C).
- No special tools required for servicing.
- Stuffing box is an integral part of the thermostatic element, allowing easy and simple maintenance of the valve.

- OPTIONS:**
- PK sensor pocket.
  - K1 cooling unit.
  - Different capillary lengths.
  - Other thermostats on request.

- USE:**
- Saturated and superheated steam.
  - Hot and superheated water.

- AVAILABLE MODELS:**
- TR40S – carbon steel.
  - TR40SS – stainless steel.

- AVAILABLE THERMOSTATS:**
- T.205 – 400 N (max. closing force).
  - T.405 – 500 N (max. closing force).

- SIZES:** 1/2" to 1"; DN 15 to DN 25.

- CONNECTIONS:**
- Flanged EN 1092-1 PN 40.
  - Flanged ASME B16.5 Class 150 or 300.

- THERMOSTAT RANGES:**
- T.205: 0 to 60 °C, 30 to 90 °C and 60 to 120 °C.
  - T.405: 0 to 120 °C and 40 to 160 °C.

- INSTALLATION:**
- Horizontal installation with the thermostat in the vertical position, in order to reduce wear.
  - In case of medium temperatures up to 150 °C, the thermostat may be fitted below or above the valve. In case of medium temperatures between 150 and 250 °C, a cooling unit type K1 has to be applied with the connection pointing downwards.
  - A "Y" strainer should be installed upstream of the valve.
  - See IMI – Installation and maintenance instructions.

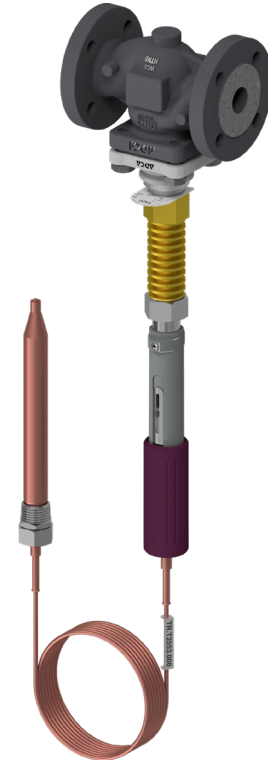

**Optional PK sensor pocket**

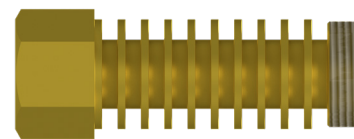

**Optional K1 cooling unit**

CE MARKING – GROUP 2 (PED – EUROPEAN DIRECTIVE)	
PN 40	CATEGORY
1/2" to 1" – DN 15 to 25	SEP

**BODY LIMITING CONDITIONS \***

TR40S			TR40SS			RELATED TEMPERATURE
PN 40	CLASS 150	CLASS 300	PN 40	CLASS 150	CLASS 300	
ALLOW. PRESS.	ALLOW. PRESS.	ALLOW. PRESS.	ALLOW. PRESS.	ALLOW. PRESS.	ALLOW. PRESS.	
40 bar	19,3 bar	50 bar	40 bar	18,4 bar	48,1 bar	-10 / 50 °C
33,3, bar	14 bar	43,9 bar	33,7 bar	13,6 bar	35,8 bar	200 °C
27,6 bar	10,2 bar	38,9 bar	29,7 bar	10,2 bar	31,6 bar	300 °C
25,7 bar	8,4 bar	36,9 bar	28,5 bar	8,4 bar	30,4 bar	350 °C
23,8 bar	6,5 bar	34,6 bar	27,4 bar	6,5 bar	29,3 bar	400 °C

\* Rating according to EN 1092-1:2018; \*\* According to EN 1759-1:2004.  
Minimum operating temperature: -10 °C.

**TR40 – T SERIES THERMOSTATS – FTO, UNBALANCED TRIM, METAL SEALING (CLASS IV)**

MODEL	SIZE	SEAT Ø (mm)	Kvs (m³/h)	STROKE (mm)	MAXIMUM PERMISSIBLE PRESSURE DROP (bar)	
					T.205	T.405
TR40 – 15/4	1/2" – DN 15	4	0,2	6	40	40
TR40 – 15/6	1/2" – DN 15	6	0,45	6	40	40
TR40 – 15/9	1/2" – DN 15	9	0,95	6	38	40
TR40 – 15/12	1/2" – DN 15	12	1,7	6	24	33
TR40 – 15/15	1/2" – DN 15	15	2,75	6	15	20
TR40 – 20/9	3/4" – DN 20	9	0,95	6,5	38	40
TR40 – 20/15	3/4" – DN 20	15	2,75	6,5	15	20
TR40 – 20/20	3/4" – DN 20	20	5	6,5	9	12
TR40 – 25/20	1" – DN 25	20	5	7	9	12
TR40 – 25/25	1" – DN 25	25	7,5	7	4,7	6

**PROPORTIONAL BAND**

The proportional band is the temperature change required for the valve to move from its fully open to fully closed position. It depends on the valve stroke (mm) and on the thermostat movement per °C (mm/°C), and is calculated as follows:

$$\text{Proportional band} = \frac{\text{Valve stroke (mm)}}{\text{Thermostat movement (mm/°C)}}$$

Thermostat movement for T.205 and T.405: 0,5 mm/°C.

A proportional band between 8 °C and 13 °C is suitable for most applications. A smaller proportional band is not ideal when heat loads vary rapidly.

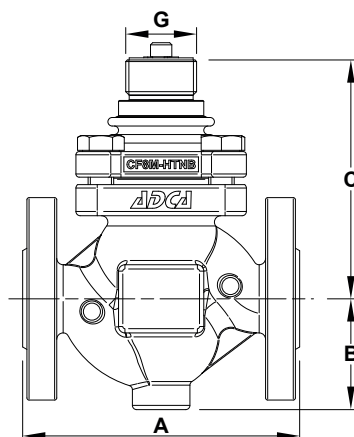

**DIMENSIONS – VALVE BODY (mm)**

SIZE	PN40					CLASS 150					CLASS 300				
	A	B	C	G	WGT. (kg)	A	B	C	G	WGT. (kg)	A	B	C	G	WGT. (kg)
1/2" – DN 15	130	52	71	1"	4,5	184	44,5	71	1"	4,2	190	47,5	71	1"	4,7
3/4" – DN 20	150	53	112	1"	5,4	184	49	112	1"	4,8	194	58,5	112	1"	6,1
1" – DN 25	160	58	117	1"	6,3	184	54	117	1"	5,4	197	62	117	1"	6,8

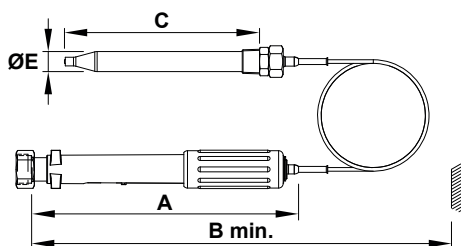

DIMENSIONS – THERMOSTAT (mm)					
MODEL	A	B	C	ØE	WEIGHT (kg)
T.205	305	405	210	22	1,8
T.405	385	525	390	22	2,6

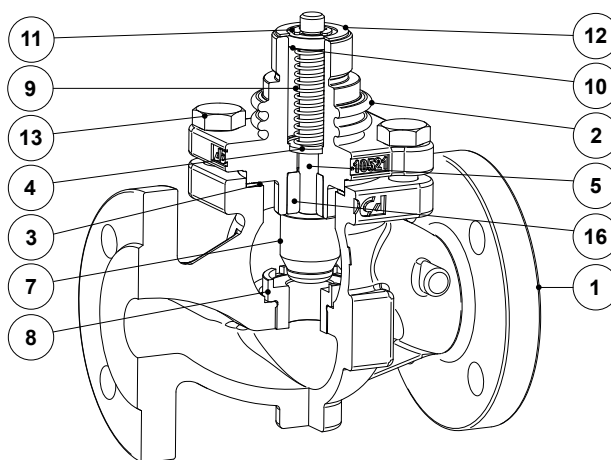

MATERIALS			
POS. No.	DESIGNATION	TR40S	TR40SS
1	Body	A216 WCB / 1.0619	AISI 351 CF8M / 1.4408
2	Bonnet	AISI 351 CF8M / 1.4408	AISI 351 CF8M / 1.4408
3	* Gasket	Stainless steel / Graphite	Stainless steel / Graphite
4	* Washer	Stainless steel A2	Stainless steel A2
5	* Stem	AISI 316 / 1.4401	AISI 316 / 1.4401
7	* Valve plug	AISI 316 / 1.4401	AISI 316 / 1.4401
8	* Seat	AISI 316 / 1.4401	AISI 316 / 1.4401
9	* Spring	AISI 302 / 1.4310	AISI 302 / 1.4310
10	* Spacer ring	AISI 304 / 1.4301	AISI 304 / 1.4301
11	* Retaining ring	Stainless steel A2	Stainless steel A2
12	* Gasket	Stainless steel / Graphite	Stainless steel / Graphite
13	Bolt	Steel 8.8	Stainless steel A2
16	Lower stem guide	Bronze CB1	Bronze CB1

\* Available spare parts.

### K1 COOLING UNITS

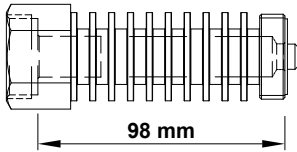

Cooling units are used as a means of protection for the stuffing box when dealing with high temperatures.

The K1 cooling unit should always be applied when medium temperatures are between 150 °C and 250 °C.

For higher temperatures as well as for all hot oil systems please consult.

### PK SENSOR POCKETS

Sensor pockets made of stainless steel can be supplied with all TR series self-acting thermostats using rod sensors. A sensor pocket, also called thermowell, is used to protect the sensor and to allow its removal while the plant is running or, e.g., the tank where it is connected to is full.

The use of sensor pockets implies delay of heat transfer to the rod sensors and, thus, a longer thermostat reaction time. This is, to some extent, counteracted by filling up the sensor pockets with a thermal conductive paste or glycerine.

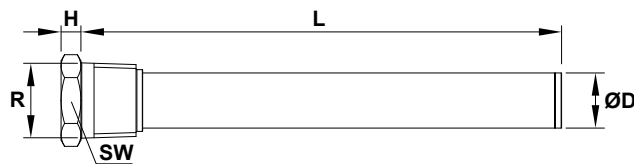

DIMENSIONS (mm)					
MODEL	ØD	H	L	R	SW
PK2	25	9	218	1"	36
PK4	25	10	390	1 1/4"	46

MATERIAL: AISI 316 / 1.4401.

INSTALLATION: The installation site for the sensor pocket is arbitrary when paste is applied. When glycerine is used, the sensor pocket must point at least slightly downwards.