

SWS SIGHT GLASSES

INSTALLATION AND MAINTENANCE INSTRUCTIONS



GENERAL INFORMATION

- These instructions must be carefully read before performing any work involving VALSTEAM ADCA products. Failure to observe these instructions may result in hazardous situations.
- These instructions describe the entire life cycle of the product. Keep them in a location that is accessible to every user and make these instructions available to every new owner of the product.
- Current regional and plant safety regulations must be considered and followed during installation, operation, and maintenance work.
- The images shown in these instructions are for illustration purposes only.
- For problems that cannot be solved with the help of these instructions, please contact VALSTEAM ADCA or its representative.

VALSTEAM ADCA ENGINEERING S.A

Zona Ind.da Guia
Pav.14 - Brejo
3105-467 Guia, Pombal
PORTUGAL
quality@valsteam.com

We reserve the right to change the design and material of this product without notice.

CONTENT

1. SAFETY INFORMATION	4
1.1. Explanation of symbols	4
1.2. Intended use	4
1.3. Qualification of personnel	5
1.4. Personal protective equipment	5
1.5. The system	5
1.6. ATEX	6
1.7. General safety notes	6
2. PRODUCT INFORMATION	8
2.1. Principle of operation	8
2.2. Certification	8
2.3. Product identification	9
2.4. Technical data	9
2.5. Factory assembly and cleaning	9
3. TRANSPORT, STORAGE AND PACKAGING	10
4. INSTALLATION	11
4.1. Preparation for installation	11
4.2. Installation procedure	12
5. START-UP	13
5.1. Preparation for start-up	13
5.2. Start-up procedure	13
6. OPERATION	14
7. SHUTDOWN	14
7.1. Shutdown procedure	14
8. PARTS LIST	15
9. MAINTENANCE	15
9.1. Maintenance procedure	15
9.2. Replacing the body seals and glass tube	16
10. DISPOSAL	16
11. RETURNING PRODUCTS	17

1. SAFETY INFORMATION

1.1. Explanation of symbols



DANGER

Hazardous situation which, if not avoided by applying the correct preventive measures, will result in fatal or serious injury and/or considerable damage to property.



WARNING

Hazardous situation which, if not avoided by applying the correct preventive measures, could result in fatal or serious injury and/or considerable damage to property.



CAUTION

Hazardous situation which, if not avoided by applying the correct preventive measures, could result in moderately severe or minor injury.



NOTICE

Situation which, if not avoided, can result in property damage or product malfunction.



NOTE

Indicates additional information, tips and recommendations.

1.2. Intended use

Refer to the markings on the device, such as nameplate and laser markings, Information Sheet (IS) and these Installation and Maintenance Instructions (IMI) to check that the product was designed for the intended use and meets the specifications used for sizing and selection. This includes checking application, material suitability, process medium, pressure and temperature as well as their respective limiting values.

VALSTEAM ADCA does not assume any responsibility for damage resulting from inappropriate use of the product, damage caused by external stresses or any other external factors. Correct installation of the product is the full responsibility of the contractor.

Inappropriate use of the product is any use other than the one described in this chapter. Inappropriate use also includes:

- Use of spare parts which are not genuine;
- Performance of maintenance work not described in these instructions;
- Use outside the limits defined by the accessories connected to the product.
- Unauthorized modifications to the product.

If the product is to be used for an application or with a fluid other than the one it was designed for, contact VALSTEAM ADCA.

1.3. Qualification of personnel

Handling, installation, operation and maintenance work must be carried out by fully trained and qualified personnel, capable of judging the work which they are assigned to perform and recognizing potentially hazardous situations. They should be trained to properly use this product according to these Installation and Maintenance Instructions.

Where a formal “Permits to Work” system is implemented in the plant it must be complied with.

1.4. Personal protective equipment

Personal protective equipment should always be worn during work in order to protect against hazards posed by e.g. the process medium, dangerous temperatures, noise, falling or projected objects and working at height. These equipment includes a helmet, safety glasses, safety harness, protective clothes, safety shoes, hearing protection, etc.

NOTE

Always assess whether you or others in your vicinity require any protective equipment. When in doubt check with the plant’s health & safety responsible personnel for details on required protective equipment.

1.5. The system

The complete system should be assessed as well as every action (e.g. closing of shut-off valves, disconnection of the power supply) to ensure this will not bring additional risk to personnel or property.

Dangerous actions that can result in a hazardous situation include isolation of protective devices such as safety valves, vents, vacuum relief valves, disconnection of electric safety devices, sensors and alarms.

1.6. ATEX

If the product is in the scope of the ATEX 2014/34/EU directive and as such bears the Ex marking, consult its specific Additional Instructions for use in Potentially Explosive Areas (IMI EX). In such cases, handling, installation, operation and maintenance work must only be performed by personnel qualified and authorized to work in potentially explosive areas.

1.7. General safety notes



DANGER

RISK OF BURSTING IN PRESSURE EQUIPMENT

Valves, ancillaries and pipelines are pressure equipment. Working above their operating limits or improper opening can lead to component bursting.

- Observe the maximum operating limits of the product and check if they are lower than those of the system in which it is being installed. Check the product Information Sheet (IS).
- Install a safety device.
- Before starting any work on the product, depressurize it and cool or heat it up to ambient temperature. This also applies to the line in which it is fitted.
- Drain the process medium from the product and all the relevant plant sections.



WARNING

RISK OF BURNS

Depending on the operating conditions, products and pipelines may get very hot or cold and cause burn injuries.

- Do not touch the product while it is hot or cold, allowing it firstly to cool down or heat up.
- Wear protective clothing and safety gloves during working operation.
- Thermally insulate tubes and product's as a preventive measure.

RISK OF INJURY CAUSED BY FLUID ATTACK ON PRODUCTS MATERIALS

The product must only be used with mediums that do not attack the materials of the product (body, gaskets, seals). Otherwise, leaks may occur, and hot and/or hazardous fluid can escape.

- Do not use the product with mediums other than the ones it was designed for. Check section 1.2 - Intended Use.
- Prevent medium contamination.



WARNING

RISK OF HEARING LOSS

Depending on the operating conditions, the product may generate loud noises.

- Wear hearing protection when in the vicinity of the product.

RISK OF INJURY CAUSED BY UNDER TIGHTENED PRODUCT OR ITS COMPONENTS

Excessively low tightening torques may cause medium to escape and/or components to be projected at high speed which may result in a hazardous situation depending on the medium, chemical properties and/or its operating conditions.

- Do not loosen any screws while the equipment is pressurized.
- Observe the specified tightening torques on these Installation and Maintenance Instructions. If the relevant torque value is not mentioned contact VALSTEAM ADCA.

RISK OF INJURY AS A RESULT OF ILLEGIBLE INFORMATION

Important information written in the product nameplate, markings and warning signs may wear overtime or get illegible due to e.g. dirt accumulation, resulting in hazardous situations and personal injury or property damage.

- Keep nameplates, markings and warning signs in a legible state, replacing when illegible, missing or damaged.



CAUTION

RISK OF INJURY DUE TO RESIDUAL PROCESS MEDIUM

Direct contact with dangerous process medium may lead to personal injury, e.g. smoke inhalation and chemical burns.

- Drain the process medium from the product and all the relevant plant sections.
- Wear protective clothing, safety gloves, mask, and eye protection.

RISK OF INJURY DUE TO IMPROPER HANDLING

Manual handling (e.g. lifting, carrying, pushing, pulling) of large and/or heavy products may result in personal injury.

- Assess the risk associated with the handling task.
- Use adequate handling methods and appropriate auxiliary handling equipment.



NOTICE

RISK OF PRODUCT DAMAGE DUE TO EXCESSIVELY HIGH TIGHTENING TORQUES

High tightening torques may lead to premature wearing of product components.

- Observe the specified tightening torques on these Installation and Maintenance Instructions. If the relevant torque value is not mentioned contact VALSTEAM ADCA.

2. PRODUCT INFORMATION

The ADCAPure SWS is a series of inline sanitary sight glasses designed to monitor flow of pure steam, water and other high purity liquids and gases.

2.1. Principle of operation

The sight glass is installed in any orientation with the flow in either direction and is used to detect, for example presence or absence of fluid flow, turbulence, colour and leaks by visual inspection of the exposed clear borosilicate glass tube.

2.2. Certification

This product has been specifically designed for use with gases and liquids which are in Group 2 of the European PED – 2014/68/EU Pressure Equipment Directive and it complies with its requirements.

CE MARKING – GROUP 2 (PED – European Directive)	
PN10	Category
1/2" to 4"	SEP



NOTE

If the product falls within category SEP it must not be CE marked, unless other directives are applicable.

This product is not in the scope of the ATEX 2014/34/EU directive as it does not have its own potential ignition source. Personnel responsible for the plant installation must assess the risks caused by static electricity and take the necessary precautionary measures to prevent static charge. These measures include e.g. connection of the product to the equipotential bonding system.

The product has been designed in accordance with ASME BPE and EHEDG guidelines.

The product surface finishing conditions and non-metallic material approvals such as

FDA and USP CL. VI are detailed in the ADCAPure specific inspection certificate.

Refer to *IS PV20.00 Technical Information Sheet - ADCAPure* for further information.

2.3. Product identification

The following items are indicated on the product nameplate or directly on its body:

- Manufacturer
- Product model (e.g. SWS)
- Pressure rating (e.g. PN 10) or maximum allowable pressure (e.g. Pmax = 10 bar)
- Nominal size (e.g. TC 1/2" BPE)
- Min. operating temperature (e.g. Tmin = -10 °C)
- Max. operating temperature (e.g. Tmax = 150 °C)
- Serial number and year of manufacturing (e.g. Reg.:17483/19)
- CE Marking (when applicable – see section 2.2 – Certification)
- EX Marking (when applicable e.g. EX h IIB T6...T3 Gb – see section 2.2 – Certification)

2.4. Technical data

For technical data including dimensions, materials, limiting conditions and versions refer to the product's respective Information Sheet (IS).

2.5. Factory assembly and cleaning

Assembly of the product is performed in a certified clean room according to ISO 14644-1 and all its components are ultrasonic cleaned and, when admissible, degreased and passivated. Such operations are performed in accordance with certified procedures and rigorous control.

3. TRANSPORT, STORAGE AND PACKAGING



WARNING

RISK DUE TO FALLING LOADS

Loads may tip or fall over resulting in damage to property, serious injury or death.

- Use suitable equipment when moving or lifting suspended loads.
- Make sure no one is standing below the suspended load.



CAUTION

RISK OF INJURY DUE TO IMPROPER HANDLING

Manual handling (e.g. lifting, carrying, pushing, pulling) of large and/or heavy products may result in personal injury such as back injury.

- Assess the risk associated with the handling task.
- Use adequate handling methods and appropriate auxiliary handling equipment.



NOTICE

RISK OF PRODUCT DAMAGE DUE TO IMPROPER STORAGE

- Do not remove any packaging or protective covers until immediately before installation at the site.
- Store the product in a solid base in a dry, cool and dust-free environment.
- Until its installation, protect it from the weather, dirt, corrosive atmospheres and other harmful influences.

RISK OF PRODUCT DAMAGE DUE TO LONG TERM STORAGE

Some product components may deteriorate with time (e.g. valve packings, seals).

- Do not store the product for more than 12 months.
- If for any reason the product must be stored for longer periods of time contact VALSTEAM ADCA.

The product is end capped and sealed with recyclable thermo shrinkable plastic film inside the clean room where it was assembled to prevent contamination as it leaves the clean environment. The product is stored in a cardboard box as it leaves VALSTEAM ADCA. Avoid removing packaging, covers and sealings until immediately before installing the product at the site.



NOTE

If the transport packaging has any shipping damage contact VALSTEAM ADCA or its representative.

Before storing and transporting the product protect it from impacts and mechanical damage, paying special care with its surface finish, sealing surfaces and other fragile parts.

4. INSTALLATION

Before performing any installation work, refer to section 1 – Safety information.



WARNING

RISK OF INJURY DUE TO INSUFFICIENT SUPPORT DURING INSTALLATION

Insufficient support of the product during installation may cause it to fall and cause personal injury.

- Ensure the product is safely held in place during installation.
- Wear protective safety shoes.



NOTICE

RISK OF PRODUCT DAMAGE DUE TO STRESS

The product is not intended to withstand external stresses that may be induced by the system to which it is being connected to.

- Make sure that the connected pipe does not subject the body to any stress (forces or torques) during installation and operation.
- Do not use the product as an elevation point.

4.1. Preparation for installation

Before installation, make sure the following conditions are met:

- The installation area has easy access and the device is to be installed in a position where operation and maintenance work can be performed safely.
- The product will be installed with proper support and free of any stresses that can be induced by the system due to e.g. thermal pipe expansions / contractions during CIP/SIP. The necessary precautions are recommended during system design.
- The pipeline where the product will be installed is designed in such a way that it

takes into account the weight of the product. The pipeline may require support on both sides next to the product, particularly if its size and weight are considerable and especially if vibrations are to be expected in the system.

- Consider good hydraulic flow control to avoid pressure surges and avoid dead legs on pipeline branches.
- Carefully inspect the unit to make sure the borosilicate glass is in perfect conditions.
- Make sure all the necessary materials and tools are readily available during installation work.
- Referring to this Installation and Maintenance Instructions (IMI), Information Sheet (IS) and nameplate, check that the product is suitable for the intended installation: temperature, medium, pressure, temperature, etc. – see section 1.2 – Intended use.
- Check that there are no foreign bodies inside the pipelines and ancillaries, flushing may be necessary. These should be thoroughly cleaned.
- Check any mounted pressure gauges and make sure they function properly.



NOTE

Assembly Drawings (AD) with assembly details and parts lists are available on request.

4.2. Installation procedure

1. Remove plastic film and other packaging, as well as the protective covers which are placed on clamps or ETO connections. Make sure the sight glass is free from foreign matter.
2. Handle the sight glass carefully to prevent damage to the glass and the surface finish of the metallic parts.
3. The sight glass can be installed in any orientation, with the flow in either direction.
4. Use appropriate gaskets on the clamp ferrule connections. Sanitary clamps must respect the system operating limit conditions.
5. When an ETO version is being installed, the welding should be carried out by qualified personnel following an appropriate orbital welding procedure.



NOTICE

RISK OF PRODUCT DAMAGE DURING WELDING PROCEDURES

Welding procedures expose heat sensitive parts such as seals and gaskets to high temperatures and can result in damage.

- Disassemble the valve and remove internal parts prior to welding.

5. START-UP

Before performing the start-up procedure, refer to section 1 – Safety Information.

The start-up procedure must be followed every time the product is put back into service.

5.1. Preparation for start-up

Before starting up, make sure the following conditions are met:

- All works on the system have been completed.
- All the necessary safety devices have been installed.
- When required, warning notices are used to alert others that the system is starting up.
- The product is correctly installed – see section 4 – Installation.
- Referring to this Installation and Maintenance Instructions (IMI), Information Sheet (IS) and nameplate, check that the product is suitable for the intended installation: temperature, medium, pressure, temperature, etc. – see section 1.2 – Intended use.
- A safety check was performed by qualified personnel. Checking for leaks, structural damage and integrity of system components.

NOTICE

RISK OF PRODUCT DAMAGE DUE TO CONTAMINATION

The plant operator is responsible for cleaning the pipelines in the plant as well as keeping the product well maintained. At start-up, the presence of small particles in the medium (dirt, scale, weld splatters, etc.) may damage the product or cause malfunction.

- Flush pipelines before start-up.
- Clean protection varnishes from pipes and flanges, leftover paint, graphite, grease, etc.
- Use a pipeline strainer or a filter.

5.2. Start-up procedure

1. Open shut-off valves slowly, until normal operating conditions are achieved. This will prevent sudden surges of pressure that can damage the unit, namely the borosilicate glass.
2. Check for any leaks.
3. Check the sight glass to ensure it is operating correctly.



NOTE

24 hours after system start-up, it is recommended to check pipe connection for leaks and retighten when necessary. Clean strainers/filters to avoid blocking.

6. OPERATION

Before operating the product refer to section 1 – Safety Information.

Immediately after completing the start-up procedure, the product is ready for operation.

7. SHUTDOWN

Before performing the shutdown procedure, refer to section 1 – Safety Information.

7.1. Shutdown procedure

1. Switch off the system and secure it so it cannot be turned on by unauthorized personnel.
2. Fully close the upstream shut-off valve, to stop the process medium from flowing through the sight glass.
3. Allow medium to cool down and completely drain it from the pipeline and sight glass.
4. Make sure the pipeline and sight glass are not under pressure and are at a safe temperature.
5. Fully close the downstream shut-off valve.
6. If the sight glass is to be removed from the pipeline – see section 3 - Transport, storage and packaging.

8. PARTS LIST

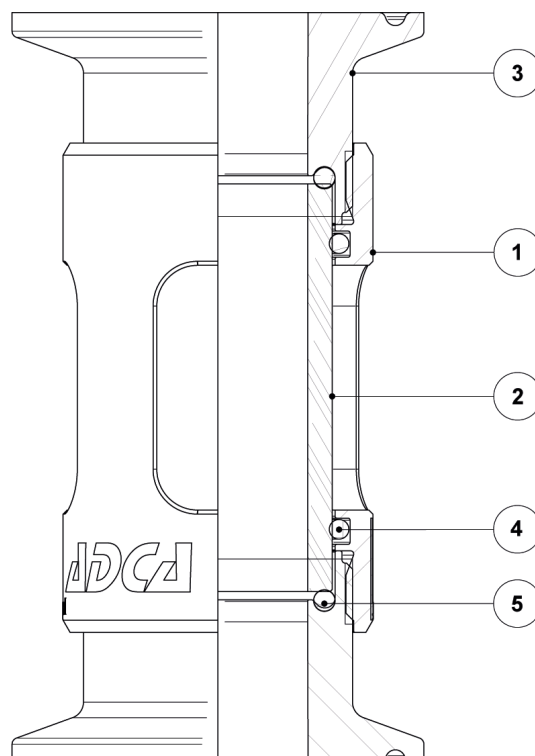

Fig. 1

POS. N°	DESIGNATION	SPARE PARTS
1	Valve body	
2	Glass	X
3	Connection ends	
4	O-ring	X
5	O-ring	X

9. MAINTENANCE

Before performing a maintenance procedure, refer to section 1 – Safety information.

The product requires maintenance to ensure that it operates correctly and safely throughout its lifetime. Maintenance work should be performed in a planned manner at periodic intervals. These intervals must be defined by the operator according to the service conditions.

9.1. Maintenance procedure

1. Make sure all necessary materials and tools are readily available during maintenance work.
2. Perform the shutdown procedure – see section 7 – Shutdown.

3. Perform the maintenance procedure – see the following sections.
4. Put the sight glass back into operation – see section 5 – Start-up.

9.2. Replacing the body seals and glass tube

1. Tightening or loosening of the connection ends (3) can be achieved by fitting ferrule adaptors with clamp end on one side and threaded end on the opposite side. These adaptors usually have two flat faces on the threaded side. One of the adaptors is secured to a vise via the flat faces and the opposite is unscrewed using a wrench on the flat faces as well.
2. Once loosened, remove the connection ends (3) and discard glass (2) and O-rings (4, 5). Thoroughly clean all surfaces.
3. Place the O-rings (4) on the body (1) grooves and apply a suitable lubricant to help slide the glass.
4. Slide glass (2) into the body (1).
5. Apply a suitable anti-seize lubricant to the connection end (3) threads.
6. Place the O-rings (5) on the connection ends (3) and loosely thread by hand ensuring that the O-rings are correctly resting in the grooves and that the glass is centred on the body.
7. Tighten securely using the same method described in point 1. Remove the adaptors.

10. DISPOSAL

Once the product has reached the end of its working life, it should be sent for disposal in accordance with the prevailing national and local regulations.

Before disposal make sure that the product is clean and free from fluid residues.

During its disposal, pay special attention to rubbers, resins and polymer components (PVC, PTFE, PP, PVDF, FKM, NBR, etc.).

Do not dispose of components and hazardous substances together with household waste.

11. RETURNING PRODUCTS

Information regarding hazards and precautionary measures to be considered due to contaminating fluids and residues or mechanical damage that may represent a health, safety or environmental risk, must be provided in writing when returning products to VALSTEAM ADCA.



WARNING

RISK DUE TO PRESENCE OF HAZARDOUS RESIDUES ON RETURNED PRODUCTS

Contaminated fluids and residues may represent an environmental risk, or risk to VALSTEAM ADCA personnel.

- Information regarding any hazards or precautionary measures to be considered must be provided in writing when returning products to VALSTEAM ADCA.
- Health and Safety information sheets relating to any substances identified as hazardous or potentially hazardous must be provided outside the packaging.
- Use Hazmat labels on the packaging.

IMPORTANT NOTE

Total or partial disregard of these Installation and Maintenance Instructions involves loss of any right to warranty.

The extent and warranty period are specified in the “General sales conditions”.