

SAFETY RELIEF VALVES SRV8

DESCRIPTION

The ADCA SRV8 series aseptic safety relief valves with angle type connections are designed for use with clean steam, air, water and other gases and liquids compatible with the construction materials. Main applications are overpressure protection on steam equipment, pressure vessels and pipelines, particularly within the food, beverage and pharmaceutical industries.

MAIN FEATURES

Completely machined from solid bar stock material.
Metal to metal or soft sealing.
Elastomer bellows to isolate the product chamber from the spring housing.
Self draining design.

STANDARD SURFACE FINISH

Internal wetted parts: $\leq 0,51$ micron Ra – SF1.
External: $\leq 0,76$ micron Ra – SF3.
Other surface conditions see IS PV20.00 E – Technical information.
Ultrasonic cleaning.

OPTIONS: Pneumatic lifting device (for CIP/SIP).
Lift indicator.
Blocking system.
Gas tight assembly.

USE: Clean steam, air, water and other gases and liquids compatible with the construction.

AVAILABLE

MODELS: SRV8.

SIZES: 3/4" x 1", 1" x 1 1/2" and 1 1/2" x 2".
DN 20 x 25, DN 25 x 40, DN 32 x 40 and
DN 40 x 50.

CONNECTIONS: ASME BPE and DIN clamp ferrules.
Others on request.

DESIGNS: DIN EN ISO 4126-1.
AD-Merkblatt-A2.
PED – Pressure Equipment Directive.

PACKAGING: Assembling and packaging in a clean room certified according to ISO 14644-1.
The product is end capped and sealed with recyclable thermo-shrinkable plastic film, to avoid contamination.



LIMITING CONDITIONS *

Valve model	SRV8
Body design conditions	PN 16
Maximum operating pressure	16 bar
Maximum operating temperature	180 °C
Minimum operating temperature	- 40 °C

* Higher or lower limits on request.

CE MARKING – GROUP 2 (PED – European Directive)

PN 16	Category
All sizes	4 (CE marked)

CE Marking: This product has been designed for use on steam, air and other gases which are in Group 2 and 1 (only oxygen, others on request) of the European PED - Pressure Equipment Directive in use and it complies with those requirements. The product carries the CE mark.

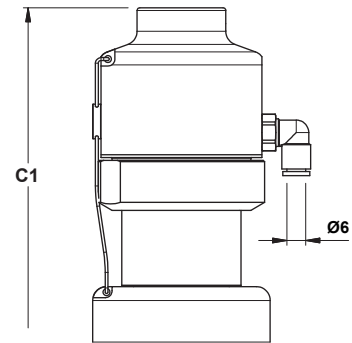
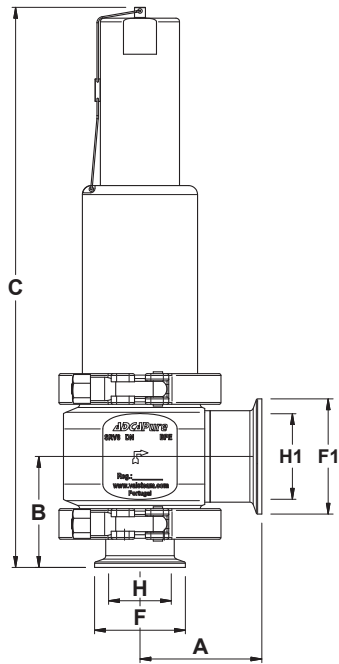

Optional pneumatic lifting device

DIMENSIONS (mm) ASME BPE

SIZE	do	A	B	C	C1 *	F	H	F1	H1	WEIGHT (kg)
3/4" x 1"	10	62,5	50,5	279	285	25	15,8	50,5	22,1	4,3
1" x 1 1/2"	13	62,5	53,5	281	287	50,5	22,1	50,5	34,8	4,4
1 1/2" x 2"	23	67,5	61,5	311	317	50,5	34,8	64	47,5	5,3

DIMENSIONS (mm) DIN

SIZE	do	A	B	C	C1 *	F	H	F1	H1	WEIGHT (kg)
DN 20 x 25	10	55,5	52,5	279	285	34	20	50,5	26	4,3
DN 25 x 40	13	55,5	55	282	288	50,5	26	50,5	38	4,4
DN 32 x 40	17	55,5	53	282	288	50,5	32	50,5	38	4,3
DN 40 x 50	23	60,5	61,5	311	317	50,5	38	64	50	5,2

* Valve with pneumatic lifting device.

Remarks: Clamp ferrules according to DIN 32676-A; Tube weld (ETO) according to DIN 11866-A (DIN 11850-2).

**SRV8
FLOW CAPACITIES
(10% overpressure in accordance with ISO 4126-1)**

SIZE	DN 20 x 25 3/4" x 1"			DN 25 x 40 1" x 1 1/2"			DN 32 x 40			DN 40 x 50 1 1/2" x 2"		
do (mm)	10			13			17			23		
Flow area (mm ²)	78,5			132,7			227			415,5		
Set Pressure	Steam (kg/h)	Air (Nm ³ /h)	Water (m ³ /h)	Steam (kg/h)	Air (Nm ³ /h)	Water (m ³ /h)	Steam (kg/h)	Air (Nm ³ /h)	Water (m ³ /h)	Steam (kg/h)	Air (Nm ³ /h)	Water (m ³ /h)
*0,5	57,01	70,57	2,81	77,95	96,49	2,87	115,25	142,67	4,59	170,76	211,39	7,05
1	77,17	94,40	3,97	109,95	134,50	4,08	168,83	206,52	6,47	256,34	313,57	9,87
2	96,34	119,26	5,06	173,32	214,56	5,73	299,91	371,26	9,09	451,04	558,35	13,80
3	137,36	171,50	5,94	243,69	304,27	7,05	414,65	517,72	11,18	639,96	799,03	16,92
4	172,30	216,50	6,66	312,82	393,08	8,19	533,64	670,55	12,72	822,32	1033,30	19,66
5	210,34	265,70	7,38	380,01	480,04	9,19	631,97	798,31	14,35	1007,39	1272,54	22,17
6	251,79	319,40	7,87	445,63	565,30	10,00	738,53	936,85	15,67	1191,15	1511,01	24,39
7	287,18	365,63	8,46	508,27	647,13	10,96	842,33	1072,45	17,02	1358,56	1729,71	26,51
8	322,48	411,86	8,93	570,74	728,95	11,81	945,86	1208,05	18,13	1525,55	1948,41	28,45
9	357,74	458,09	9,52	633,15	810,77	12,39	1049,30	1343,65	19,20	1692,37	2167,11	30,36
10	393,02	504,32	9,98	695,60	892,59	13,21	1152,79	1479,24	20,25	1859,29	2385,81	31,95
11	428,16	550,55	10,46	757,80	974,41	13,85	1255,86	1614,84	21,23	2025,53	2604,51	33,51
12	463,16	596,78	10,93	819,73	1056,23	14,47	1358,50	1750,44	22,18	2191,07	2823,21	35,00
13	498,26	643,01	11,38	881,86	1138,05	15,06	1461,47	1886,04	23,08	2357,15	3041,91	36,43
14	533,26	689,24	11,81	943,81	1219,87	15,63	1564,13	2021,63	23,96	2522,72	3260,61	37,80
15	568,44	735,47	12,22	1006,07	1301,69	16,18	1667,32	2157,23	24,80	2689,16	3479,31	39,13
16	603,55	781,70	12,62	1068,21	1383,51	16,71	1770,30	2292,83	25,61	2855,25	3698,01	40,41

* Lower set pressures on request.

SRV OPTIONS

PNEUMATIC LIFTING DEVICE *	LIFT INDICATOR	BLOCKING SYSTEM

* For do = 23 mm and set pressures above 7 bar, a special high capacity pneumatic lifting device is required.

MATERIALS

POS. N°	DESIGNATION	MATERIAL
1	Valve body	AISI 316L / 1.4404
1A	Seat	AISI 316L / 1.4404
2	* Seat disc	AISI 316L / 1.4404
3	Lifting bell	AISI 316L / 1.4404
4	* O-ring	EPDM
5	Ball	AISI 316 / 1.4401
6	Spindle	AISI 316L / 1.4404
7	Lift stopper	AISI 316L / 1.4404
8	* Pin	AISI 301 / 1.4310
9	* Bellows	EPDM
10	Fixing nut	AISI 316L / 1.4404
11	Bellows fixing ring	AISI 316L / 1.4404
12	* O-ring	EPDM
13	Guide bushing	AISI 316L / 1.4404
14	Bushing	PTFE + 15% GF
15	Bolts	Stainless Steel A2-70
16	Split ring	AISI 316L / 1.4404
17	Spring plate	AISI 316L / 1.4404
18	* Spring	AISI 302HT / 1.4310
19	Bonnet	AISI 316L / 1.4404
20	Adjusting screw	AISI 316L / 1.4404
21	Lock nut	AISI 316L / 1.4404
22	Cap	AISI 316L / 1.4404
23	Clamp	AISI 316 / 1.4401
24	Connector	AISI 316L / 1.4404
25	O-ring	EPDM
26	O-ring	EPDM
27	Piston	AISI 316L / 1.4404
28	O-ring	EPDM
29	Spring	AISI 302 / 1.4300
30	Pin	AISI 301 / 4.4310
31	Cover	AISI 316L / 1.4404
32	Lock nut	AISI 316L / 1.4404
33	Pneumatic fitting	Nickel plated brass
34	Test gag screw	AISI 316 / 1.4401
35	Gag lock nut	AISI 316 / 1.4401
36	Proximity sensor	Nickel plated brass
37	Lock nut	Stainless Steel A4-70
38	O-ring	EPDM
39	O-ring	EPDM

* Available spare parts.

Remarks: FDA / USP Class VI seals certificate on request.

All valves have a serial number. In case of non-standard valves, this number must be supplied if spare parts are ordered.

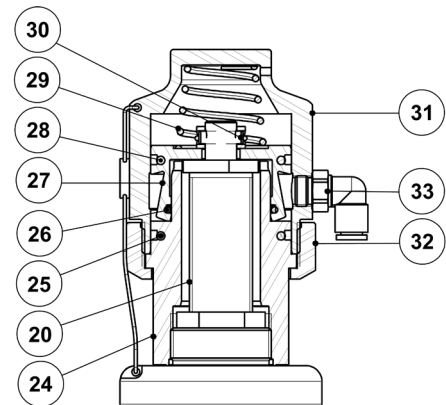
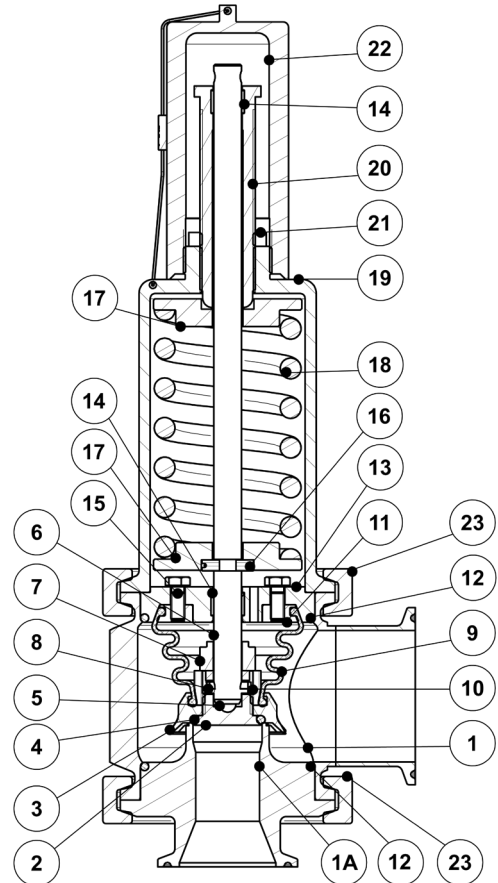

Pneumatic lifting device

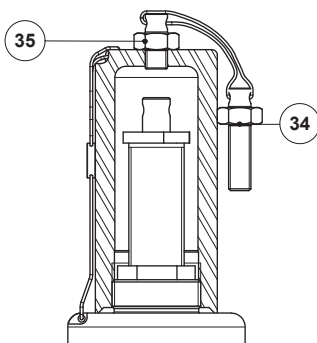

Blocking system

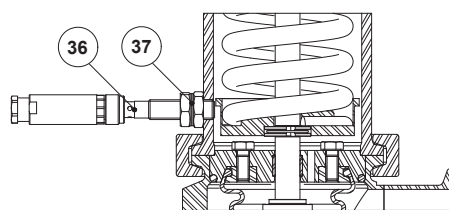

Lift indicator

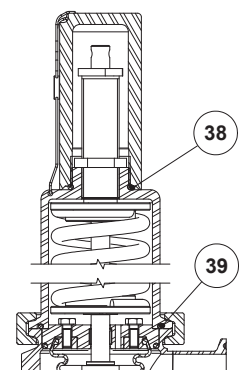

Gas tight assembly

ORDERING CODES SRV8												
Valve model	SV8	L	E	E	1	X	XX	005	DI	20	E	
SRV8 - AISI 316L / 1.4404 safety relief valve	SV8											
Application												
Liquids		L										
Gases		G										
Oxygen (degreased)		O										
Bellows												
EPDM			E									
Valve head												
EPDM				E								
Metal to metal				M								
FPM / Viton				V								
Top cap												
Top cap					1							
Pneumatic lifting device					2							
High capacity pneumatic lifting device (for do = 23 mm and set pressures > 7 bar)					3							
Top cap and gas tight assembly					4							
Pneumatic lifting device and gas tight assembly					5							
High capacity pneumatic lifting device and gas tight assembly					6							
Surface finish a)												
Standard surface finish						X						
Mirror mechanical polished external surfaces (SF1)						P						
Electropolished internal wetted parts (SF5)						E						
Special features												
None								XX				
Lift indicator								LX				
Blocking system								XB				
Lift indicator and blocking system								LB				
Set pressure												
0,5 bar								005				
...												
1 bar								010				
...												
7,6 bar								076				
...												
16 bar								160				
Pipe connection												
Clamp ferrule ASME BPE									D			
Clamp ferrule DIN (DIN 32676-A)									F			
Tube weld (ETO) according to ASME BPE									DI			
Tube weld (ETO) according to DIN 11866-A (DIN 11850-2)									FI			
Hygienic male threads DIN (DIN 11851)									G1			
Aseptic male threads DIN (DIN 11864-1 Form A)									G2			
Size												
3/4" x 1" or DN 20 x 25										20		
1" x 1 1/2" or DN 25 x 40										25		
DN 32 x DN 40										32		
1 1/2" x 2" or DN 40 x 50										40		
Special valves / Extras												
Full description or additional codes have to be added in case of non-standard combination											E	

a) Consult IS PV20.00 (Technical information) for further details and other surface finish options.