

SRT10 CHECK VALVES

INSTALLATION AND MAINTENANCE INSTRUCTIONS



GENERAL INFORMATION

- These instructions must be carefully read before performing any work involving VALSTEAM ADCA products. Failure to observe these instructions may result in hazardous situations.
- These instructions describe the entire life cycle of the product. Keep them in a location that is accessible to every user and make these instructions available to every new owner of the product.
- Current regional and plant safety regulations must be considered and followed during installation, operation, and maintenance work.
- The images shown in these instructions are for illustration purposes only.
- For the problems that cannot be solved with the help of these instructions, please contact the VALSTEAM ADCA or its representative.

VALSTEAM ADCA ENGINEERING S.A

Zona Ind.da Guia
Pav.14 - Brejo
3105-467 Guia, Pombal
PORTUGAL
quality@valsteam.com

We reserve the right to change the design and material of this product without notice.

CONTENT

| | |
|---|-----------|
| 1. SAFETY INFORMATION | 4 |
| 1.1. Explanation of symbols | 4 |
| 1.2. Intended use | 4 |
| 1.3. Qualification of personnel | 5 |
| 1.4. Personal protective equipment | 5 |
| 1.5. The system | 5 |
| 1.6. ATEX | 6 |
| 1.7. General safety notes | 6 |
| 2. PRODUCT INFORMATION | 8 |
| 2.1. Principle of operation | 8 |
| 2.2. Certification | 9 |
| 2.3. Product identification | 9 |
| 2.4. Technical data | 10 |
| 2.5. Factory assembly and cleaning | 10 |
| 3. TRANSPORT, STORAGE AND PACKAGING | 10 |
| 4. INSTALLATION | 12 |
| 4.1. Preparation for installation | 12 |
| 4.2. Installation procedure | 13 |
| 5. START-UP | 14 |
| 5.1. Preparation for start-up | 14 |
| 5.2. Start-up procedure | 14 |
| 6. OPERATION | 15 |
| 7. SHUTDOWN | 15 |
| 7.1. Shutdown procedure | 15 |
| 8. PARTS LIST | 16 |
| 9. MAINTENANCE | 17 |
| 9.1. Maintenance procedure | 17 |
| 9.2. Replacing the body seals and plug assembly | 17 |
| 9.3. Tightening torques | 17 |
| 10. TROUBLESHOOTING | 18 |
| 11. DISPOSAL | 18 |
| 12. RETURNING PRODUCTS | 18 |

1. SAFETY INFORMATION

1.1. Explanation of symbols



DANGER

Hazardous situation which, if not avoided by applying the correct preventive measures, will result in fatal or serious injury and/or considerable damage to property.



WARNING

Hazardous situation which, if not avoided by applying the correct preventive measures, could result in fatal or serious injury and/or considerable damage to property.



CAUTION

Hazardous situation which, if not avoided by applying the correct preventive measures, could result in moderately severe or minor injury.



NOTICE

Situation which, if not avoided, can result in property damage or product malfunction.



NOTE

Indicates additional information, tips and recommendations.

1.2. Intended use

Refer to the markings on the device, such as nameplate and laser markings, Information Sheet (IS) and these Installation and Maintenance Instructions (IMI) to check that the product was designed for the intended use and meets the specifications used for sizing and selection. This includes checking application, material suitability, process medium, pressure and temperature as well as their respective limiting values.

VALSTEAM ADCA does not assume any responsibility for damage resulting from inappropriate use of the product, damage caused by external stresses or any other external factors. Correct installation of the product is the full responsibility of the contractor.

Inappropriate use of the product is any use other than the one described in this chapter.

- Use of spare parts which are not genuine;
- Performance of maintenance work not described in these instructions;
- Use outside the limits defined by the accessories connected to the product.
- Unauthorized modifications to the product.

If the product is to be used for an application or with a fluid other than the one it was designed for, contact VALSTEAM ADCA.

1.3. Qualification of personnel

Handling, installation, operation and maintenance work must be carried out by fully trained and qualified personnel, capable of judging the work which they are assigned to perform and recognizing potentially hazardous situations. They should be trained to properly use this product according to these Installation and Maintenance Instructions.

Where a formal “Permits to Work” system is implemented in the plant it must be complied with.

1.4. Personal protective equipment

Personal protective equipment should always be worn during work in order to protect against hazards posed by e.g. the process medium, dangerous temperatures, noise, falling or projected objects, working at height. These equipment includes a helmet, safety glasses, safety harness, protective clothes, safety shoes, hearing protection, etc.



NOTE

Always assess whether you or others in your vicinity require any protective equipment. When in doubt check with the plant's health & safety responsible personnel for details on required protective equipment.

1.5. The system

The complete system should be assessed as well as every action (e.g. closing of shut-off valves, disconnection of the power supply) to ensure this will not bring additional risk to personnel or property.

Dangerous actions that can result in a hazardous situation include isolation of protective devices such as safety valve, vents, vacuum relief valves, disconnection of electric safety devices, sensors and alarms.

1.6. ATEX

If the product is in the scope of the ATEX 2014/34/EU directive and as such bears the Ex marking, consult its specific Additional Instructions for use in Potentially Explosive Areas (IMI EX). In such cases, handling, installation, operation and maintenance work must only be performed by personnel qualified and authorized to work in potentially explosive areas.

1.7. General safety notes



DANGER

RISK OF BURSTING IN PRESSURE EQUIPMENT

Valves, ancillaries and pipelines are pressure equipment. Working above their operating limits or improper opening can lead to component bursting.

- Observe the maximum operating limits of the product and check if they are lower than those of the system in which it is being installed. Check the product Information Sheet (IS).
- Install a safety device.
- Before starting any work on the product, depressurize it and cool or heat it up to ambient temperature. This also applies to the line in which it is fitted.
- Drain the process medium from the product and all the relevant plant sections.



WARNING

RISK OF BURNS

Depending on the operating conditions, products and pipelines may get very hot or cold and cause burn injuries.

- Do not touch the product while it is hot or cold, allowing it firstly to cool down or heat up.
- Wear protective clothing and safety gloves during working operation.
- Thermally insulate tubes and product's as a preventive measure.

RISK OF INJURY CAUSED BY FLUID ATTACK ON PRODUCTS MATERIALS

The product must only be used with mediums that do not attack the materials of the product (body, gaskets, seals). Otherwise, leaks may occur, and hot and/or hazardous fluid can escape.

- Do not use the product with mediums other than the ones it was designed for. Check section 1.2 - Intended Use.
- Prevent medium contamination.



WARNING

RISK OF HEARING LOSS

Depending on the operating conditions, the product may generate loud noises.

- Wear hearing protection when in the vicinity of the product.

RISK OF INJURY CAUSED BY UNDER TIGHTENED PRODUCT OR ITS COMPONENTS

Excessively low tightening torques may cause medium to escape or and/or components to be projected at high speed which may result in a hazardous situation depending on the medium, chemical properties and/or its operating conditions.

- Do not loosen any screw while the equipment is pressurized.
- Observe the specified tightening torques on these Installation and Maintenance Instructions. If the relevant torque value is not mentioned contact VALSTEAM ADCA.

RISK OF INJURY AS A RESULT OF ILLEGIBLE INFORMATION

Important information written in the product nameplate, markings and warning signs may wear overtime or get illegible due to e.g. dirt accumulation, resulting in hazardous situations and personal injury or property damage.

- Keep nameplates, markings and warning signs in a legible state, replacing when illegible, missing or damaged.



CAUTION

RISK OF INJURY DUE TO RESIDUAL PROCESS MEDIUM

Direct contact with dangerous process medium may lead to personal injury, e.g. smoke inhalation and chemical burns.

- Drain the process medium from the product and all the relevant plant sections.
- Wear protective clothing, safety gloves, mask, and eye protection.

RISK OF INJURY DUE TO IMPROPER HANDLING

Manual handling (e.g. lifting, carrying, pushing, pulling) of large and/or heavy products may result in personal injury.

- Assess the risk associated with the handling task.
- Use adequate handling methods and appropriate auxiliary handling equipment.



NOTICE

RISK OF PRODUCT DAMAGE DUE TO EXCESSIVELY HIGH TIGHTENING TORQUES

High tightening torques may lead to premature wearing of product components.

- Observe the specified tightening torques on these Installation and Maintenance Instructions. If the relevant torque value is not mentioned contact VALSTEAM ADCA.

2. PRODUCT INFORMATION

The SRT10 full stainless steel disk check (non-return) valves have a compact design and are specially designed for use with clean steam, hot condensate and other liquids and gases. They are particularly recommended for the food, pharmaceutical, fine chemical and cosmetic industries to prevent reverse flow in high purity systems.

The SRT10 are concentric valves designed for vertical installation and their eccentric variation, the SRTH10, are designed for horizontal installations and allow self-drainability of the process medium.

2.1. Principle of operation

A spring (4) pushes the plug assembly (5) to keep the SRT10 closed against upstream pressure. When the force exerted by the upstream pressure exceeds the force of the spring, the SRT10 will open and allow flow of the process medium. If reverse flow occurs, the spring force and the downstream pressure force exerted on the backside of the plug will keep the valve closed. In case of valves installed in vertical installations the weight of the valve plug and stem will apply opening or closing force depending on its orientation. This is more significant in bigger valve sizes.

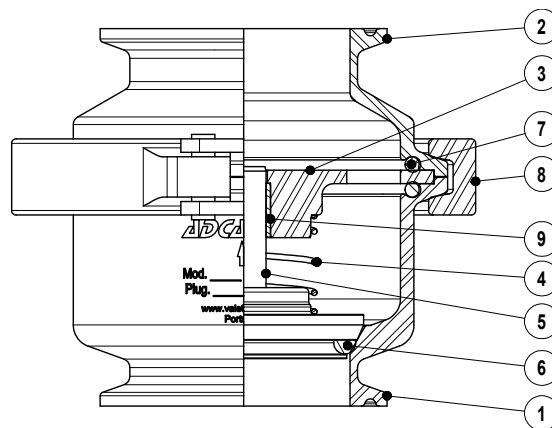

Fig.1

2.2. Certification

This product has been specifically designed for use with gases and liquids which are in Group 2 of the European PED – 2014/68/EU Pressure Equipment Directive and it complies with its requirements.

| SRT10 – CE MARKING – GROUP 2 (PED – European Directive) | |
|---|----------|
| PN10 | Category |
| 1/2" to 4" | SEP |

NOTE

If the product falls within category SEP it must not be CE marked, unless other directives are applicable.

This product is not in the scope of the ATEX 2014/34/EU directive as it does not have its own potential ignition source. Personnel responsible for the plant installation must assess the risks caused by static electricity and take the necessary precautionary measures to prevent static charge. These measures include e.g. connection of the product to the equipotential bonding system.

The product has been designed in accordance with ASME BPE and EHEDG guidelines.

The product surface finishing conditions and non-metallic material approvals such as FDA and USP CL. VI are detailed in the ADCAPure specific inspection certificate.

Refer to *IS PV20.00 Technical Information Sheet - ADCAPure* for further information.

2.3. Product identification

The following items are indicated on the product nameplate or directly on its body:

- Manufacturer
- Product model (e.g. P130L)
- Pressure rating (e.g. PN16) or maximum allowable pressure (e.g. Pmax = 16 bar)
- Nominal size (e.g. TC 1/2" BPE)
- Min. operating temperature (e.g. Tmin = -10°C)
- Max. operating temperature (e.g. Tmax = 150°C)
- Flow direction (indicated by an arrow)
- Serial number and year of manufacturing (e.g. Reg.:17483/19)
- CE Marking (when applicable – see section 2.2 – Certification)
- EX Marking (when applicable e.g. EX h IIB T6...T3 Gb – see section 2.2 – Certification)

2.4. Technical data

For technical data including dimensions, materials, limiting conditions and versions refer to the product respective Information Sheet (IS).

| FLOW RATE COEFFICIENTS (m ³ /h) | | | | | | | |
|--|------|------|----|--------|------|-----|-----|
| Valve size | 1/2" | 3/4" | 1" | 1 1/2" | 2" | 3" | 4" |
| Kvs | 2 | 6 | 11 | 23,5 | 43,5 | 104 | 169 |

| MINIMUM OPENING PRESSURES WITH STANDARD SPRING (mbar) | | | | | | |
|---|--------|--|--------|--|--------|--|
| SIZE | D.P. ↑ | | D.P. → | | D.P. ↓ | |
| 1/2" | 52 | | 42 | | 32 | |
| 3/4" | 50 | | 40 | | 32 | |
| 1" | 36 | | 30 | | 20 | |
| 1 1/2" | 40 | | 38 | | 32 | |
| 2" | 20 | | 18 | | 14 | |
| 3" | 40 | | 28 | | 16 | |
| 4" | 45 | | 35 | | 21 | |

→ : Flow direction. Approximate values for valve with EPDM seals.

2.5. Factory assembly and cleaning

Assembly of the product is performed in a certified clean room according to ISO 14644-1 and all its components are cleaned and, when admissible, degreased and passivated. Such operations are performed in accordance with certified procedures and rigorous control.

3. TRANSPORT, STORAGE AND PACKAGING

 **WARNING**

RISK DUE TO FALLING LOADS
 Loads may tip or fall over resulting in damage to property, serious injury or death.

- Use suitable equipment when moving or lifting suspended loads.
- Make sure no one is standing below the suspended load.



CAUTION

RISK OF INJURY DUE TO IMPROPER HANDLING

Manual handling (e.g. lifting, carrying, pushing, pulling) of large and/or heavy products may result in personal injury such as back injury.

- Assess the risk associated with the handling task.
- Use adequate handling methods and appropriate auxiliary handling equipment.



NOTICE

RISK OF PRODUCT DAMAGE DUE TO IMPROPER STORAGE

- Do not remove any packaging or protective covers until immediately before installation at the site.
- Store the product in a solid base in a dry, cool and dust-free environment.
- Until its installation, protect it from the weather, dirt, corrosive atmospheres and other harmful influences.

RISK OF PRODUCT DAMAGE DUE TO LONG TERM STORAGE

Some product components may deteriorate with time (e.g. valve packings, seals).

- Do not store the product for more than 12 months.
- If for any reason the product must be stored for longer periods of time contact VALSTEAM ADCA.

The product is end capped and sealed with recyclable thermo shrinkable plastic film inside the clean room where it was assembled to prevent contamination as it leaves the clean environment. The product is stored in a cardboard box as it leaves VALSTEAM ADCA. Avoid removing packaging, covers and sealings until immediately before installing the product at the site.



NOTE

If the transport packaging has any shipping damage contact VALSTEAM ADCA or its representative.

Before storing and transporting the product protect it from impacts and mechanical damage, paying special care with its surface finish, sealing surfaces and other fragile parts.

4. INSTALLATION

Before performing any installation work, refer to section 1 – Safety information.



WARNING

RISK OF INJURY DUE TO INSUFFICIENT SUPPORT DURING INSTALLATION

Insufficient support of the product during installation may cause it to fall and cause personal injury.

- Ensure the product is safely held in place during installation.
- Wear protective safety shoes.



NOTICE

RISK OF PRODUCT DAMAGE DUE TO STRESS

The product is not intended to withstand external stresses that may be induced by the system to which it is being connected to.

- Make sure that the connected pipe does not subject the body to any stress (forces or torques) during installation and operation.
- Do not use the product as an elevation point.

4.1. Preparation for installation

Before installation, make sure the following conditions are met:

- The installation area has easy access and the device is to be installed in a position where operation and maintenance work can be performed safely.
- The product will be installed with proper support and free of any stresses that can be induced by the system due to e.g. thermal pipe expansions / contractions during CIP/SIP. The necessary precautions are recommended during system design.
- The pipeline where the product will be installed is designed in such a way that it takes into account the weight of the product. The pipeline may require support on both sides next to the product, particularly if its size and weight are considerable and especially if vibrations are to be expected in the system.
- Consider good hydraulic flow control to avoid pressure surges and avoid dead legs on pipeline branches.
- The product is not damaged.
- Make sure all the necessary materials and tools are readily available during installation work.
- Referring to this Installation and Maintenance Instructions (IMI), Information Sheet (IS) and nameplate, check that the product is suitable for the intended installation:

temperature, medium, pressure, temperature, etc. – see section 1.2 – Intended use.

- Check that there are no foreign bodies inside the pipelines and ancillaries, flushing may be necessary. These should be thoroughly cleaned.
- Check any mounted pressure gauges and make sure they function properly.



NOTE

Assembly Drawings (AD) with assembly details and parts lists are available on request.

4.2. Installation procedure

1. Remove plastic film and other packaging, as well as protective covers which are placed on clamps or ETO connections. Make sure the check valve is free from foreign matter.
2. Handle the product carefully to ensure its surface finish is not damaged.
3. Vertical installation position is recommended in case of the SRT10 due to its concentric design. Horizontal installation position is recommended in case of the SRT10 due to its eccentric design to guarantee self-drainability. For this reason, the eccentric connection must be positioned at the lowest point.
4. The check valve has an arrow or inlet/outlet designations, be sure that it is installed in the appropriate direction according to fluid flow.
5. When a clamp ferrule version is being installed, use appropriate gaskets. Sanitary clamps must respect the system operating limit conditions.
6. When an ETO version is being installed, the welding should be carried out by qualified personnel following an appropriate orbital welding procedure. Prior to welding, disassemble the valve and remove internal parts.



NOTICE

RISK OF PRODUCT DAMAGE DURING WELDING PROCEDURES

Welding procedures expose heat sensitive parts such as seals and gaskets to high temperatures and can result in damage.

- Disassemble the valve and remove internal parts prior to welding.

5. START-UP

Before performing the start-up procedure, refer to section 1 – Safety information.

The start-up procedure must be followed every time the product is put back into service.

5.1. Preparation for start-up

Before starting up, make sure the following conditions are met:

- All works on the system have been completed.
- All the necessary safety devices have been installed.
- When required, warning notices are used to alert others that the system is starting up.
- The product is correctly installed – see section 4 – Installation.
- Referring to these Installation and Maintenance Instructions (IMI), Information Sheet (IS) and nameplate, check that the product is suitable for the intended installation: temperature, medium, pressure, temperature, etc. – see section 1.2 – Intended use.
- A safety check was performed by qualified personnel. Checking for leaks, structural damage and integrity of system components.



NOTICE

RISK OF PRODUCT DAMAGE DUE TO CONTAMINATION

The plant operator is responsible for cleaning the pipelines in the plant as well as keeping the product well maintained. At start-up, the presence of small particles in the medium (dirt, scale, weld splatters, etc.) may damage the product or cause malfunction.

- Flush pipelines before start-up.
- Clean protection varnishes from pipes and flanges, leftover paint, graphite, grease, etc.
- Use a pipeline strainer or a filter.

5.2. Start-up procedure

1. Open shut-off valves slowly, until normal operating conditions are achieved. This will prevent sudden surges of pressure that can damage the check valve.
2. Check for any leaks.
3. Check the product to ensure it is operating correctly.



NOTE

24 hours after system start-up, it is recommended to check pipe connection for leaks and retighten when necessary. Clean strainers/filters to avoid blocking.

6. OPERATION

Before operating the product refer to section 1 – Safety information.

Immediately after completing the start-up procedure, the product is ready for operation.

7. SHUTDOWN

Before performing the shutdown procedure, refer to section 1 – Safety information.

7.1. Shutdown procedure

1. Switch off the system and secure it so it cannot be turned on by unauthorized personnel.
2. Fully close the upstream shut-off valve, to stop the process medium from flowing through the check valve.
3. Allow medium to cool down and completely drain it from the pipeline and check valve.
4. Make sure the pipeline and check valve are not under pressure and are at a safe temperature.
5. Fully close the downstream shut-off valve.
6. If the check valve is to be removed from the pipeline – see section 3 - Transport, storage and packaging.

8. PARTS LIST

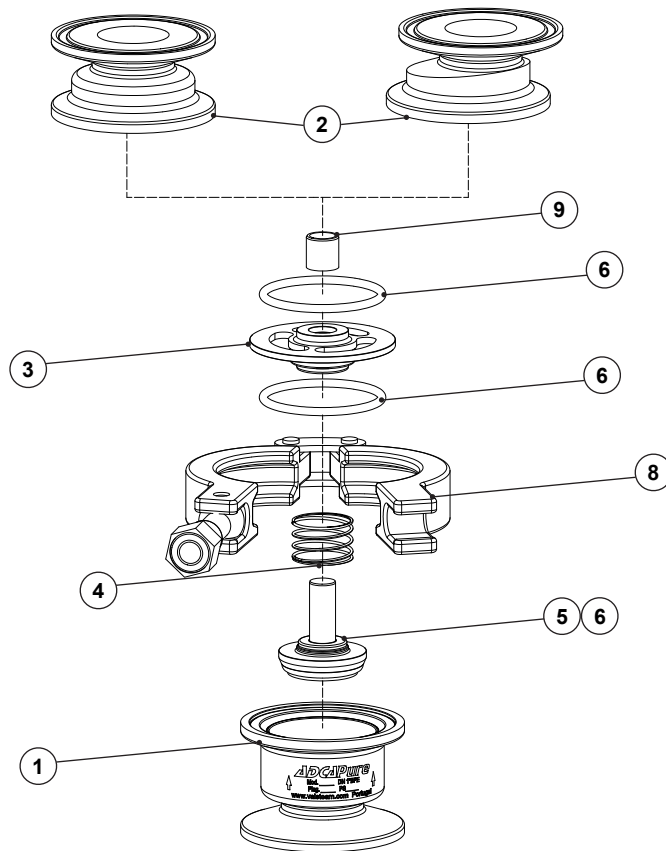

| POS. N° | DESIGNATION | SPARE PARTS |
|---------|-------------------|-------------|
| 1 | Valve inlet body | |
| 2 | Valve outlet body | |
| 3 | Guide plate | |
| 4 | Spring | |
| 5 | Valve and stem | X |
| 6 | Valve seal | X |
| 7 | Body seals | X |
| 8 | Safety clamp | |
| 9 | Plain bearing | |

Fig.2

9. MAINTENANCE

Before performing a maintenance procedure, refer to section 1 – Safety information.

The product requires maintenance to ensure that it operates correctly and safely throughout its lifetime. Maintenance work should be performed in a planned manner at periodic intervals. These intervals must be defined by the operator according to the service conditions.

9.1. Maintenance procedure

1. Make sure all the necessary materials and tools are readily available during maintenance work.
2. Perform the shutdown procedure – see section 7 – Shutdown.
3. Perform the maintenance procedure – see the following sections.
4. Put the product back into operation – see section 5 – Start-up.

9.2. Replacing the body seals and plug assembly

1. For valves with clamp ferrule connections, remove the sanitary clam from the inlet and outlet connections and completely remove the valve from the system.
2. Remove the body safety clamp (8) and separate the valve inlet and outlet body (1, 2).
3. Remove all internal components, checking for signs of any wear or damage. This includes two body seals (7), guide plate (3), spring (4) and plug assembly (5).
4. Fit the spring on the groove of the new plug assembly and slide the plug assembly into the guide plate.
5. Install a new seal on the inlet body seal groove and position the assembled set in the valve inlet body against the seal.
6. Fit the second body seal in the outlet body seal groove and bring the two body halves together.
7. Apply suitable anti-seize lubricant, if admissible, on the thread of the body safety clamp. Fit the body safety clamp in place, tightening the nut with the recommended torque – see section 9.3 – Tightening torques.

9.3. Tightening torques

| POS. N° | DESIGNATION | TORQUE (Nm) |
|---------|-------------------|-------------|
| | | All sizes |
| 8 | Body safety clamp | 4-5 |

10. TROUBLESHOOTING

Before applying any corrective measure, refer to section 1 – Safety information.

If the malfunction cannot be solved with the help of the following table, contact VALSTEAM ADCA or its representative.

| Malfunction | Possible cause | Corrective measure |
|-------------------------|---|---|
| Check valve is leaking. | Foreign matter is stuck between seat and plug assembly. | <ul style="list-style-type: none"> Open and clean the check valve. |
| | The sealing surfaces are damaged/worn. | <ul style="list-style-type: none"> Replace plug assembly. If the seat surface on the valve inlet body is damaged contact VALSTEAM ADCA. |

11. DISPOSAL

Once the product has reached the end of its working life, it should be sent for disposal in accordance with the prevailing national and local regulations.

Before disposal make sure that the product is clean and free from fluid residues.

During its disposal, pay special attention to rubbers, resins and polymer components (PVC, PTFE, PP, PVDF, FKM, NBR, etc.).

Do not dispose of components and hazardous substances together with household waste.

12. RETURNING PRODUCTS

Information regarding hazards and precautionary measures to be considered due to contaminating fluids and residues or mechanical damage that may represent a health, safety or environmental risk, must be provided in writing when returning products to VALSTEAM ADCA.



WARNING

RISK DUE TO PRESENCE OF HAZARDOUS RESIDUES ON RETURNED PRODUCTS

Contaminated fluids and residues may represent an environmental risk, or risk to VALSTEAM ADCA personnel.

- Information regarding any hazards or precautionary measures to be considered must be provided in writing when returning products to VALSTEAM ADCA.
- Health and Safety information sheets relating to any substances identified as hazardous or potentially hazardous must be provided outside the packaging.
- Use Hazmat labels on the packaging.

IMPORTANTE NOTE

Total or partial disregard of these Installation and Maintenance Instructions involves loss of any right to warranty.

The extent and warranty period are specified in the “General sales conditions”.