

DN25x25 - DN50x50

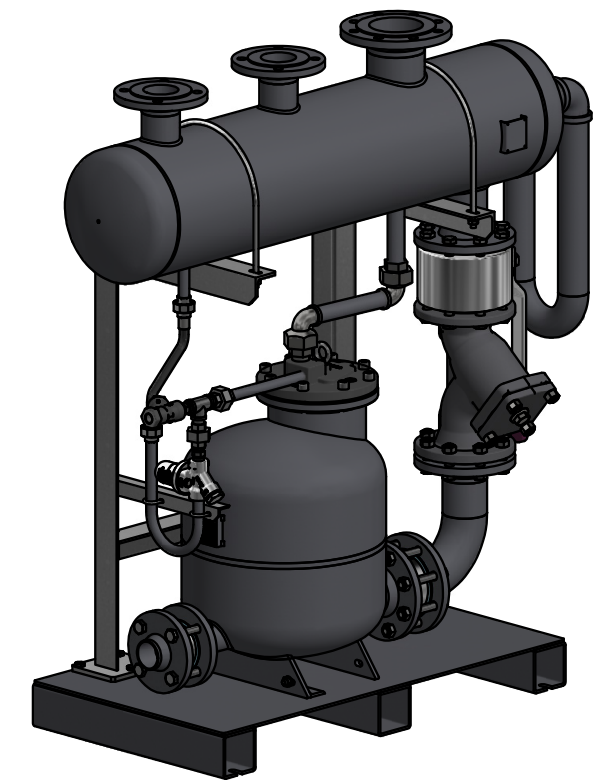

DN80x50

Dimensions (mm)	
A	
B	
C	
D	
d1	
d2	
d3	
d4	
d5	
E	
F	
G	
H	

8	1	Overflow		2"	
7	1	Steam trap	UCX41+_____	1/2"	
6	1	Y Strainer	IS140	1/2"	
5	1	Y Strainer	IS16F		
4	1	Wafer type ball valve MWS1	MWS1		
3	1	Receiver			
2B	2	Disc check valve	RD40		
2A	2	Disc check valve	RD40		
1	1	Pressure operate pump	POPS		
Ref.	Quant.	Designation	Model	Size	Drawing request

				Proc. 0.260	
Description ADCAMAT PUMP POPS-K Packaged vented system DN25-DN80 Steam operated				Des.N° ADPOPK50.06.1840	
				Rev.: 01 Em: 22.06.22 Page: 1 de 1	