

INSTALLATION AND MAINTENANCE INSTRUCTIONS AE16 AIR ELIMINATOR

GENERAL

- These instructions must be carefully read before any work involving products supplied by VALSTEAM ENGINEERING S.A. is undertaken.
- The installation procedure is a critical stage in a life of an air eliminator and care should be taken to avoid damage to the eliminator or equipment.

Warning!

- At start up, the presence of small particles in the water (dirt, scale, weld splatters, etc) may cause an imperfect closure of the seat. If this occurs, proceed to an accurate cleaning.
- Do not touch the equipment without appropriate protection during working operation because it may conduct heat if the used fluid is at high temperature.
- Before starting maintenance be sure that the equipment is not pressurized or hot.
- The equipments must be used within the working temperature and pressure limits laid down for them, otherwise they may fail (refer to nameplate and/or IS- Information Sheet).
- Do not remove the nameplate attached to the equipment. Serial number and other useful information is stamped on it.

INSTALLATION



- Before to install remove plastic covers placed on flanges or connection ends. The equipment has an arrow or Inlet/Outlet designations. Be sure that it will be installed on the appropriate direction.
- Install the air eliminator in the highest point of the system, where the air tends to collect. It must be installed absolutely vertically using an air bottle. A drip pipe is recommended to discharge to a safe place.

LIMITING CONDITIONS	
PMA: Max. allowable pressure	16bar
TMA: Max. allowable temperature	250°C
PMO: Max. operating pressure	14bar
TMO: Max. operating temperature	200°C

APPLICATION LIMITS	
Minimum liquid specific weight:	0.75 Kg/dm ³
AE16/6 Max.differential pressure:	6bar
AE16/16 Max.differential pressure:	16bar
AE16SS Max.differential pressure:	12bar

Installation area requirements:

- The installation area should have easy access and provide enough space for maintenance and removing operations.
- The installation area should have the necessary firing system to prevent damage of the equipment due to over temperature/pressure cause by fire.

MAINTENANCE

- We recommend that the air eliminators are serviced as necessary. Regular maintenance is not particularly recommended.
- When reassembling make sure that all gasket faces are clean and always use a new gasket. Tighten cover bolts uniformly in a diagonal sequence.
- For further information refer to the relevant AE16 brochure or consult our Sales Office.

CE Marking:

This product has been designed for use on steam and water which are in Group 2 of the PED-European Pressure Equipment Directive 97/23/EC and it comply with those requirements.

The product fall within category SEP and must not be CE marked.

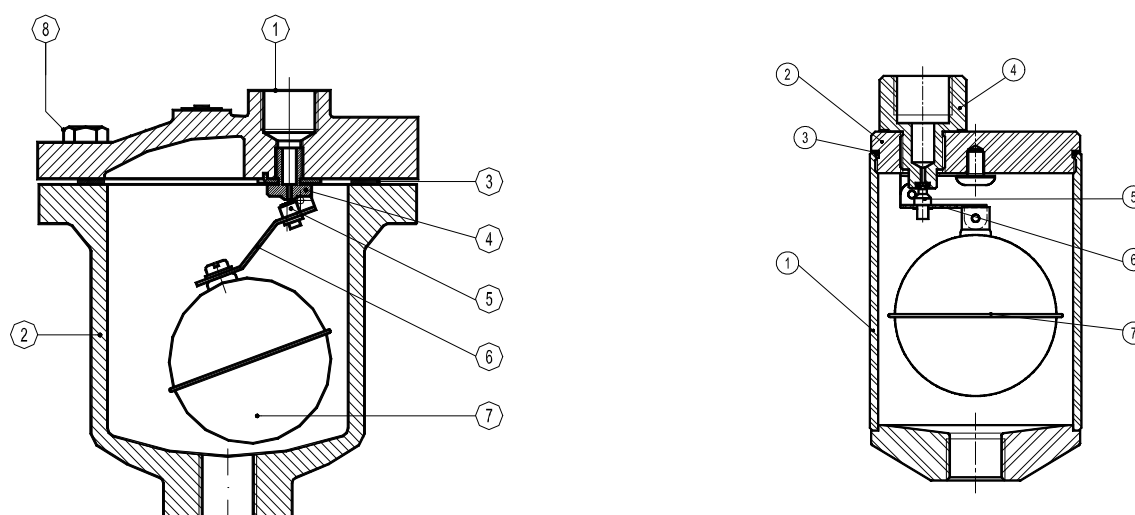
PARTS LIST FOR AE16 AIR ELIMINATORS

CODE	DESIGNATION	TRAP SIZE DN	POS.NR.	QTY.
A.95.8006.015	Valve, seat, float & gasket	½" - 1"	3, 4, 5, 6, 7	1 set
A.95.8006.115	Float & gasket	½" - 1"	3, 7	1 set

PARTS LIST FOR AE16SS AIR ELIMINATORS

CODE	DESIGNATION	TRAP SIZE DN	POS.NR.	QTY.
A.95.8017.015	S.valve, seat, float & gasket	½"	3, 4, 5, 6, 7	1 set
A.95.8017.115	Float & gasket	½"	3, 7	1 set

Recommended tightening torques AE16:

POS.NR.	TRAP SIZE DN	Nm
4	½" - 1"	50-55
8	½" - 1"	25-30

Remarks: Tighten cover bolts uniformly.

Recommended tightening torques AE16SS:

POS.NR.	TRAP SIZE DN	Nm
4	½"	60-65
2	½"	15-20

TYPICAL INSTALLATION

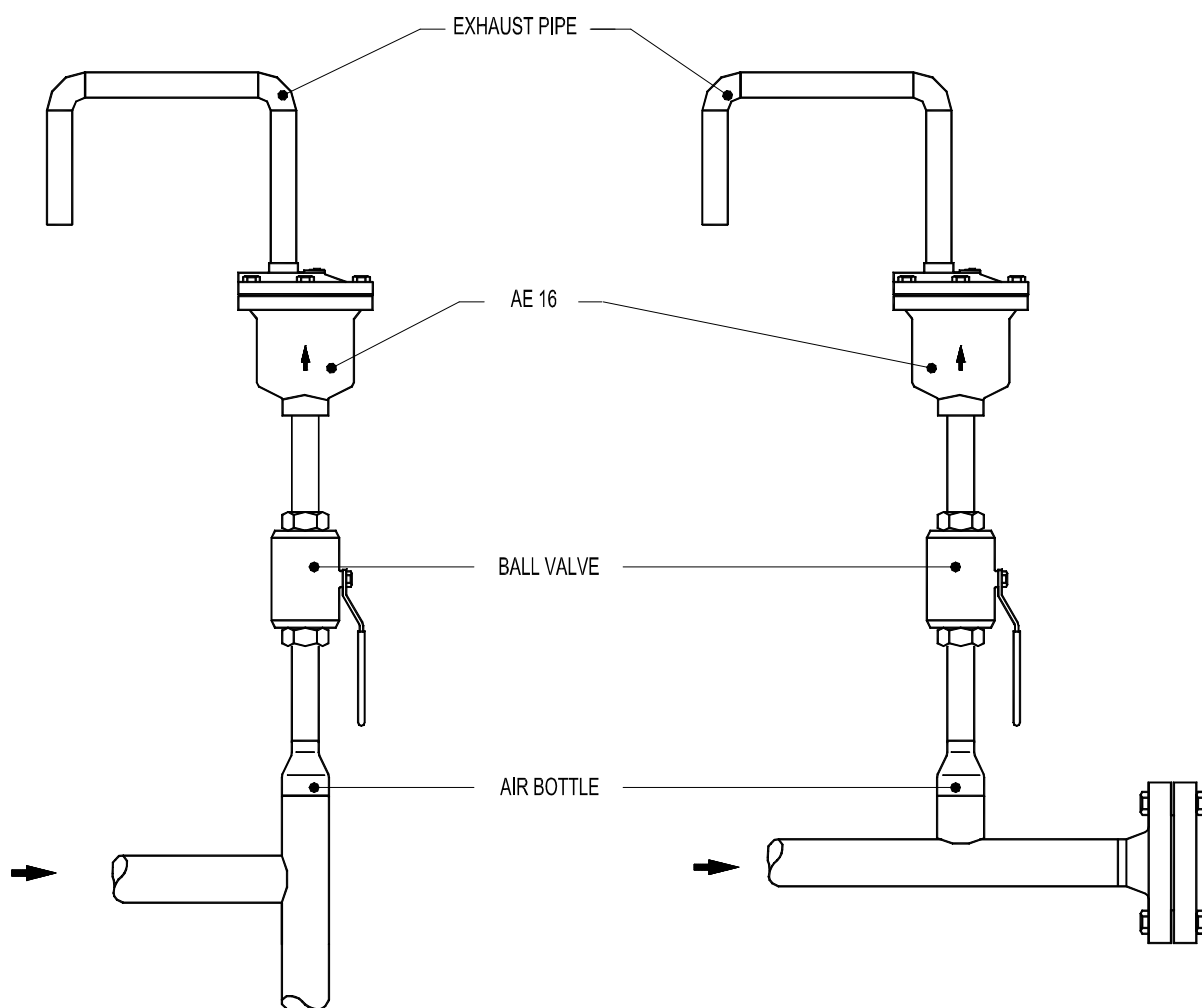

ATTENTION

- **LOSS OF WARRANTY:** Total or partial disregard of above instructions involves loss of any right to warranty.