

HYGIENIC STEAM FILTER ISC16

DESCRIPTION

The ISC16 high efficiency filters are used to remove contaminated particles from gases such as steam and compressed air.

The optimized construction of these units offers low differential pressure at high flow rates.

All sizes are built in two halves. Up to 3" / DN 80 they are joined by a food industry fitting according to DIN 11851 and the larger sizes DN 100 to DN 200 by flat flanges fixed with bolts and nuts.

The replaceable filter elements are made of sintered austenitic stainless steel.

MAIN FEATURES

Several retention rates available.

Good durability against aggressive gases.

Porosity level is more than 50% ensuring high particle and dirt load capacity as well as good flow rate at a low differential pressure.

Regeneration by ultrasonic bath.

STANDARD SURFACE FINISH

Internal parts: $\leq 0,76$ micron Ra – SF3.

External: Satin bead blast finish – 1,6 micron Ra.

Other surface conditions see IS PV20.00 E – Technical information.

USE: Steam, compressed air and other gases (Group 2).

AVAILABLE MODELS: ISC16 – AISI 304 / 1.4301 stainless steel.
ISC16I – AISI 316L / 1.4404 stainless steel.

RETENTION RATES: 1, 5 and 25 micron.

SIZES: 1/4" to 3".
DN 10 to DN 80 (DN 100 to DN 200 on request).

CONNECTIONS: Female threaded ISO 7 Rp or NPT.
Flanged EN 1092-1 PN 16.
Flanged ASME B16.5 Class 150.
Others on request.

INSTALLATION: Horizontal installation always with the drain connection pointing downwards.
See IMI – Installation and maintenance instructions.



CE MARKING – GROUP 2 (PED – European Directive)

Ps 16 bar	Ps 12 bar	Category
1/4" to 1 1/2" – DN 10 to 40	–	SEP
2"L to 3"L – DN 50L to 80L	–	1 (CE marked)
–	3"H – DN 80H	2 (CE marked)

LIMITING CONDITIONS

Maximum allowable pressure	DN 10 to 80L	16 bar
	DN 80H	12 bar
Maximum allowable temperature		200 °C
Minimum allowable temperature		- 20 °C
Maximum operating pressure	EPM	8,5 bar @ 178 °C
	FLUORAZ	10 bar @ 200 °C
Minimum operating temperature		0 °C
Maximum differential pressure		5 bar
Maximum cold hydraulic test pressure	DN 10 to 80L	20,8 bar
	DN 80	15,6 bar

Remark: maximum recommended pressure drop of 0,07 bar.

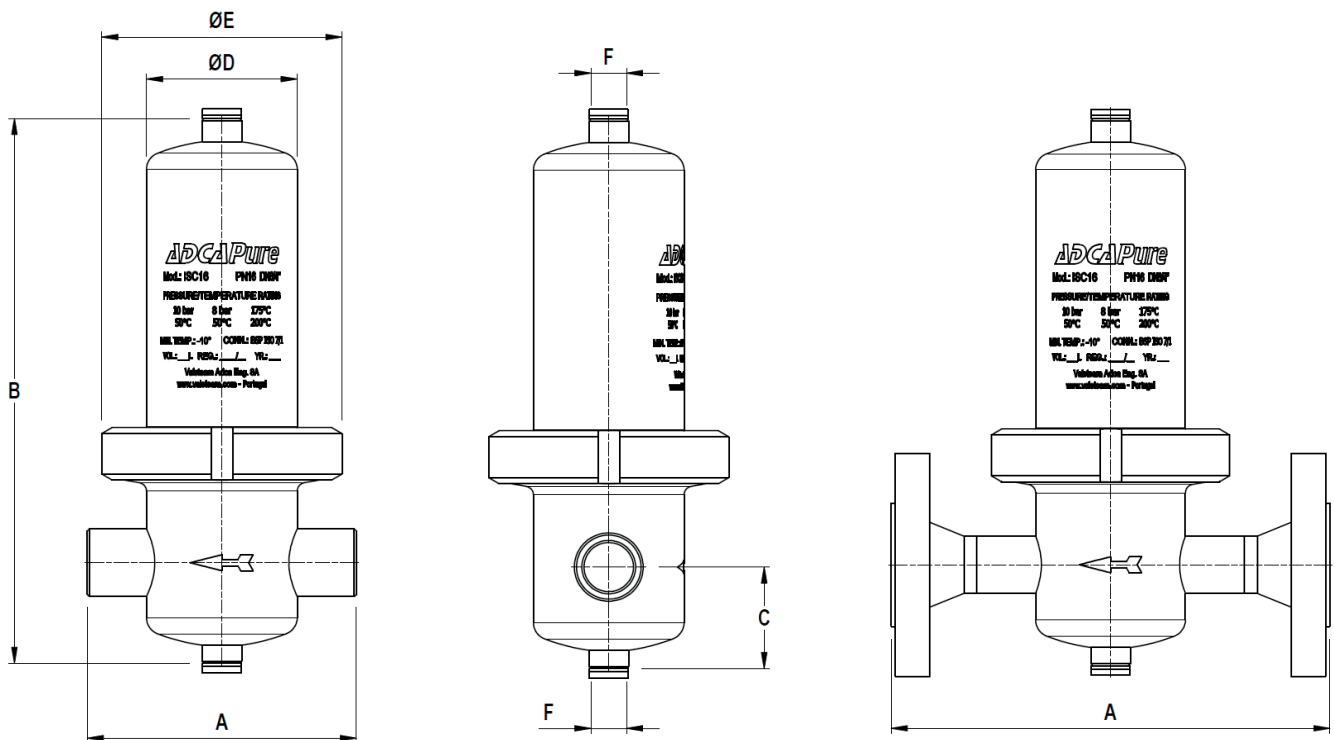

DIMENSIONS (mm) ISO

SIZE *	A THREADED	A TUBE WELD	A PN 16	A CLASS 150	B	C	D	E	F	VOL. ** (L)	WEIGHT ** (kg)
1/4" – DN 08	108	108	–	–	220	55	70	112	1/4"	0,6	1,8
3/8" – DN 10	108	108	180	–	248	55	70	112	1/4"	0,7	1,9
1/2" – DN 15	108	108	180	203	248	55	70	112	1/4"	0,7	2
3/4" – DN 20	125	125	202	230	272	55	70	112	1/4"	0,8	2,2
1" – DN 25	125	125	212	247	298	74	85	127	1/4"	1,3	2,8
1 1/4" – DN 32	140	140	220	254	350	74	85	127	1/4"	1,6	3,2
1 1/2" – DN 40	170	170	254	294	388	93	104	148	1/4"	2,8	4,6
2"L – DN 50L	170	170	260	297	463	93	104	148	1/4"	3,2	4,7
2"H – DN 50H	170	170	260	297	590	93	104	148	1/4"	4,5	5,3
2 1/2" – DN 65	216	216	306	356	740	107	129	178	1/4"	8,9	8,3
3"L – DN 80L	216	216	316	356	1002	111	129	178	1/4"	12,2	9,7
3"H – DN 80H	240	240	340	380	1027	113	154	210	1/4"	17,8	13,3

* Suffix L corresponds to low capacity design; suffix H corresponds to high capacity design.

** Volume and weight correspond to flanged EN 1092-1 PN 16 design. Other designs may have slightly different values.

Remark: larger sizes up to DN 200 on request.

MATERIALS			
POS. N°	DESIGNATION	ISC16	ISC16I
1	Filter housing bowl	AISI 304 / 1.4301	AISI 316L / 1.4404
	Flanges	AISI 304 / 1.4301 **	AISI 316L / 1.4404 **
2	Filter housing cover	AISI 304 / 1.4301	AISI 316L / 1.4404
3	* Seal	EPM, FLUORAZ	EPM, FLUORAZ
4	Closing ring	AISI 304 / 1.4301	AISI 304 / 1.4301
5	* Filter element	Sintered AISI 316L	Sintered AISI 316L
	Filter end caps	AISI 304 / 1.4301	AISI 304 / 1.4301
6	* Filter seal o-rings (2)	EPM; FLUORAZ	EPM; FLUORAZ
7	Plug	AISI 304 / 1.4301	AISI 304 / 1.4301
8	Gasket	PTFE	PTFE

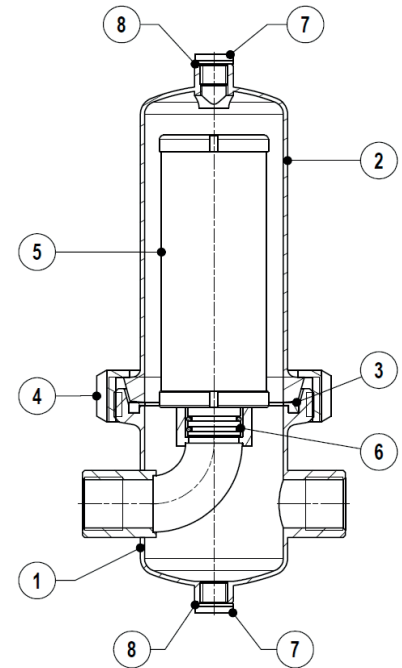

* Available spare parts; ** Can be supplied in the following materials:
 ISC16: 1.4307 / AISI 304L; 1.4541 / AISI321; 1.4401 / AISI 316; 1.4404 / AISI316L; 1.4571 / AISI316Ti.
 ISC16I: 1.4404 / AISI316L; 1.4571 / AISI316Ti.
 FDA seals certificate on request.
 All filters have a serial number. In case of non-standard filters this number must be supplied if spare parts are ordered.

TYPICAL INSTALLATION – FILTERED STEAM PRESSURE REDUCING STATION

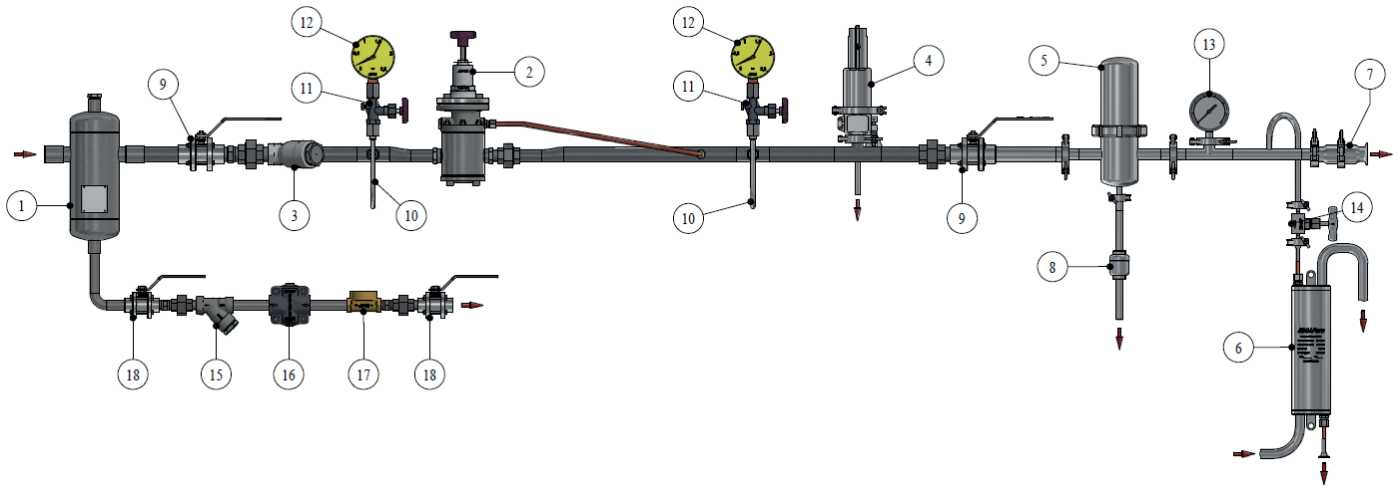

MATERIALS			
POS. N°	DESIGNATION	POS. N°	DESIGNATION
1	ADCA S16S Steam centrifugal humidity separator	10	ADCA GSU Gauge siphon
2	ADCA PRV47 Pilot operated pressure regulator	11	ADCA GC400 Gauge cock
3	ADCA IS140 Y Strainer	12	ADCA MAN100 Pressure gauge
4	ADCAPure Safety valve	13	ADCAPure SMAN-63R Pressure gauge
5	ADCAPure ISC16 Culinary steam filter	14	ADCAPure NV400P Sanitary needle valve
6	ADCAPure SC32P Sample cooler	15	ADCA IS140 Y Strainer
7	ADCAPure SRT10	16	ADCA FLT17 Float and thermostatic steam trap
8	ADCA TSS22 Steam trap	17	ADCA SW12 Sight glass
9	ADCA M3i1 Three piece ball valve	18	ADCA M3S1 Three piece ball valve

ORDERING CODES – ISC16 FILTER HOUSING							
Filter model	ISC16	.	P	A	.	08	
ISC16 – AISI 304 / 1.4301 filter housing	ISC16						
ISC16I – AISI 316L / 1.4404 filter housing	ISC16I						
Housing seal material							
EPM (up to 180 °C)			P				
FLUORAZ (up to 200 °C)			F				
Pipe connection							
Female threaded ISO 7 Rp				A			
Female threaded NPT ASME B1.20.1				C			
Tube weld				H			
Flanged EN 1092-1 PN 16				L			
Flanged ASME B16.5 Class 150				U			
Size							
1/4" or DN 08						08	
3/8" or DN 10						10	
...						...	
2"L or DN 50L						50L	
2"H or DN 50H						50H	
...						...	
3"L or DN 80L						80L	
3"H or DN 80H						80H	
Special / Extras							
Full description or additional codes have to be added in case of non-standard combination							E

ORDERING CODES – FILTER ELEMENT							
Filter element model	ISFE	.	P	1030	.	01	
ISFE – AISI 316L / 1.4404 filter element	ISFE						
Filter to housing sealing o-rings							
Without sealing o-rings			X				
EPM (up to 180 °C)			P				
FLUORAZ (up to 200 °C)			F				
Filter size according to housing DN connection							
1/4" or DN 08				0310			
3/8" or DN 10				0410			
1/2" or DN 15				0420			
3/4" or DN 20				0520			
1" or DN 25				0525			
1 1/4" or DN 32				0725			
1 1/2" or DN 40				0730			
2"L or DN 50L				1030			
2"H or DN 50H				1530			
2 1/2" or DN65				2030			
3"L or DN 80L				3030			
3"H or DN80H				3050			
Retention rate							
1 micron						01	
5 micron						05	
25 micron						25	
Special / Extras							
Full description or additional codes have to be added in case of non-standard combination							E

Order example:

1 ADCAPure filter housing ISC16 with EPM seals, female threaded NPT, 2"L – Code: ISC16.PC.50L

1 ISFE filter element with 5 micron retention rate for the above mentioned filter – Code: ISFE.P1030.05

Remark: it is recommended to always have a second filter element, in order to ensure minimum downtime when replacing the one in use after saturation.