

AIR AND GAS FLOAT TRAPS FA17G

DESCRIPTION

The FA17G series are fully automatic ball float traps, extremely compact in dimension and light in weight, specially designed for draining water from compressed air lines.

Usual applications include aftercoolers, separators and compressed air mains.

MAIN FEATURES

Modulating discharge.

Unaffected by sudden or wide load and pressure changes.

OPTIONS: Horizontal reversible inlet connections.

USE: Compressed air and non corrosive gases compatible with the construction.

AVAILABLE

MODELS: FA17G – SG iron.

SIZES: 1 1/2" to 2"; DN 40 to DN 50.

CONNECTIONS: Female threaded ISO 7 Rp or NPT.
Flanged EN 1092-2 PN 16.
Flanged ASME B16.5 Class 150 lb.

INSTALLATION: Standard horizontal installation – flow from right to left (R-L).
Vertical installation with the flow from top to bottom (V).
See IMI – Installation and maintenance instructions.

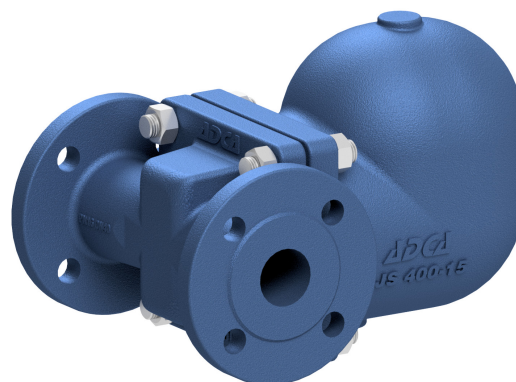

APPLICATION LIMITS	
--------------------	--

Minimum liquid specific weight	0,75 kg/dm ³
Maximum working differential pressure	14 bar

CE MARKING – GROUP 2 (PED – European Directive)	
---	--

PN 16	Category
1 1/2" to 2" – DN 40 to 50	SEP

BODY LIMITING CONDITIONS		
--------------------------	--	--

FLANGED PN 16 *	FLANGED CLASS 150 **	RELATED TEMPERATURE
ALLOWABLE PRESSURE	ALLOWABLE PRESSURE	
16 bar	15,4 bar	100 °C
15,5 bar	14,6 bar	150 °C
14,7 bar	13,8 bar	200 °C
13,9 bar	12,1 bar	250 °C

PMO – Maximum operating pressure: 14 bar;

TMO – Maximum operating temperature: 200 °C;

* According to EN 1092-2:2007; ** According to EN 1759-1:2004;

Body limiting conditions PN 16 or below, depending on the type of connections adopted. Rating PN 16 for threaded, SW and BW versions.

FLOW RATE CAPACITY (kg/h)														
---------------------------	--	--	--	--	--	--	--	--	--	--	--	--	--	--

MODEL	SIZE	DIFFERENTIAL PRESSURE (bar)												
		0,5	1	1,5	2	3	4	6	7	8	9	10	12	14
FA17G	1 1/2" to 2" DN 40 to 50	370	515	605	720	900	1005	1250	1340	1500	1560	1620	1750	1890

DIMENSIONS (mm)

SIZE	THREADED							PN 16			CLASS 150		
	A	B	C	D	E	H	WEIGHT (kg)	F	B	WEIGHT (kg)	F	B	WEIGHT (kg)
1 1/2" - DN 40	210	248	79	208	131	1/4" NPT	16,9	230	248	20,3	230	248	19,1
2" - DN 50	210	248	79	208	131	1/4" NPT	17,5	230	248	20,7	230	248	20,5

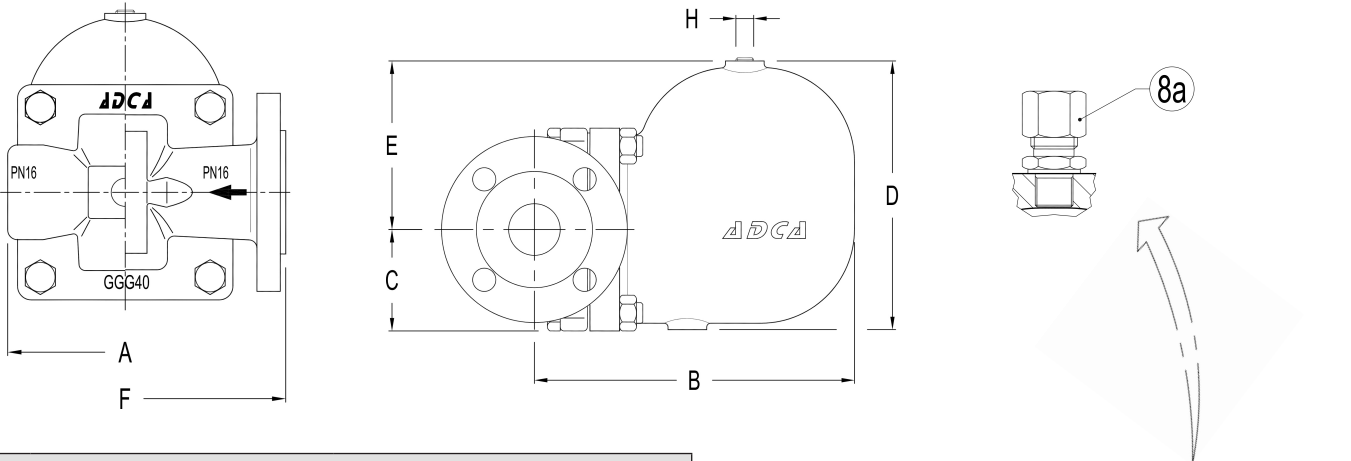

MATERIALS

POS. N°	DESIGNATION	MATERIAL
1	Body	GJS-400-15 / 0.7040
2	Cover	GJS-400-15 / 0.7040
3	* Gasket	Stainless steel / Graphite
4	* Seat	AISI 304 / 1.4301
5	* Valve	AISI 304 / 1.4301
6	* Lever	AISI 304 / 1.4301
7	* Float	AISI 304 / 1.4301
8	Plug	Stainless steel
8A	** Compression fitting	Stainless steel or Steel Fe/Zn
9	Bolts	Steel 8.8

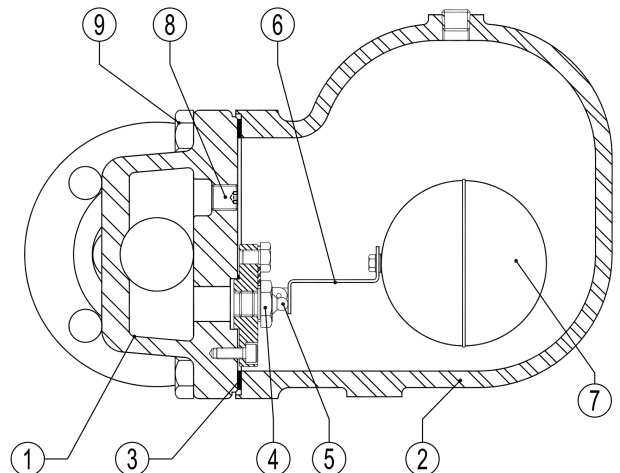

* Available spare parts.
** Optional, against extra price.

TYPICAL INSTALLATION

