

BIMETALLIC STEAM TRAPS AND AIR VENTS BM35

DESCRIPTION

The BM35 series bimetallic steam traps and air vents are simple and robust traps, recommended for steam process applications where condensate sensible heat can be recovered, steam tracing lines, drip points, storage tank coils, steam air venting, etc. The use of condensate sensible heat reduces steam consumption.

MAIN FEATURES

- Modulating discharge.
- Discharges condensate below steam temperature.
- Excellent air discharge.
- Operates on superheated steam.
- Unaffected by water hammer and vibrations.
- Built-in strainer.

USE: Saturated and superheated steam.

AVAILABLE

MODELS: BM35 – carbon steel.

SIZES: 1/2" to 1"; DN 15 to DN 25.

CONNECTIONS: Female threaded ISO 7 Rp or NPT.
Flanged EN 1092-1 PN 40 or PN 63.
Flanged ASME B16.5 Class 300 or 600.
Socket weld (SW) ASME B16.11.
Butt weld (BW) ASME B16.25.

INSTALLATION: Horizontal installation recommended, can be installed in any position.
See IMI – Installation and maintenance instructions.



CE MARKING – GROUP 2 (PED – European Directive)

PN 63	Category
1/2" to 1" – DN 15 to 25	SEP

BODY LIMITING CONDITIONS			
FLANGED PN 40 *	FLANGED PN 63 / CLASS 600 *	FLANGED CLASS 300 **	RELAT. TEMP.
ALLOW. PRESSURE	ALLOW. PRESSURE	ALLOW. PRESSURE	
40 bar	63 bar	50 bar	50 °C
30,4 bar	48 bar	41,8 bar	250 °C
27,6 bar	43,5 bar	38,9 bar	300 °C
18,5 bar	29,1 bar	28,7 bar	425 °C

Operating pressure: 2 to 35 bar.

* Acc. to EN 1092-1:2018. ** Acc. to EN 1759-1:2004.

Body limiting conditions PN 63 or below, depending on the type of connection adopted. Rating PN 63 for threaded, SW and BW versions.

FLOW RATE CAPACITY (kg/h)

MODEL	SIZE	DIFFERENTIAL PRESSURE (bar)												
		2	4	6	8	10	12	16	18	20	24	26	32	35
BM35	1/2" to 1" A DN 15 to 25 A	550	780	880	900	920	935	950	980	1000	1030	1080	1130	1160
BM35	1/2" to 1" B DN 15 to 25 B	1500	1700	2000	2200	2500	2700	2990	3150	3400	3750	3880	4030	4200

A: Condensate discharge at 10 °C below saturation temperature; B: Cold water capacity around 20 °C.

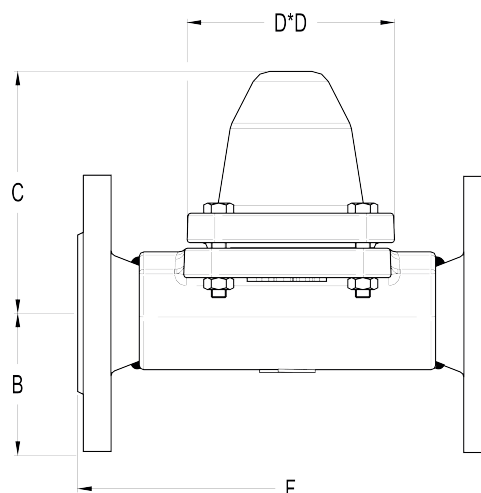
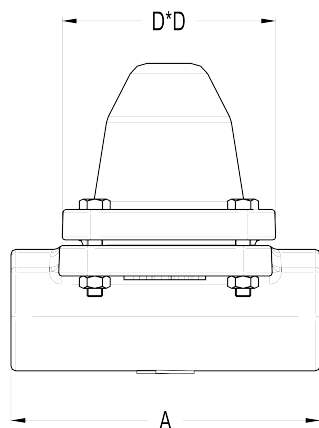

DIMENSIONS (mm)

SIZE	THREADED / SW / BW				PN 40			PN 63			CLASS 300			CLASS 600		
	A	C	D	WGT. (kg)	B	F *	WGT. (kg)	B	F *	WGT. (kg)	B	F *	WGT. (kg)	B	F *	WGT. (kg)
1/2" – DN 15	160	120	115	6,3	47,5	230	7,9	52,5	230	8,8	47,5	230	8,2	47,5	230	8,2
3/4" – DN 20	160	120	115	6,3	52,5	230	8,5	65	230	11,1	59	230	9,4	59	230	9,4
1" – DN 25	160	120	115	6,3	57,5	230	9,1	70	230	11,8	62	230	10,2	62	230	10,2

* Different face to face dimensions on request.

MATERIALS

POS. N°	DESIGNATION	MATERIAL
1	Body	A105 / 1.0432 (Equiv. P250GH)
2	Cover	A105 / 1.0432 (Equiv. P250GH)
3	* Gasket	Stainless steel / Graphite
4	* Valve assembly	Hardened stainless steel
5	* Strainer screen	AISI 304 / 1.4301
6	* Seat gasket	AISI 304 / 1.4301
7	Studs	A193 Gr. B7
7A	Nuts	A194 Gr. 2H

* Available spare parts.

