

BIMETALLIC STEAM TRAPS AND AIR VENTS BM20i

DESCRIPTION

The BM20i is a series of robust and efficient bimetallic steam traps and air vents. These steam traps are recommended for steam process applications where sensible heat can be recovered, such as steam tracing lines, drip points, storage tank coils and steam air venting.

MAIN FEATURES

- Modulating discharge.
- Discharges condensate below steam temperature.
- Excellent air discharge.
- Operates on superheated steam.
- Unaffected by water hammer and vibrations.
- Built-in strainer.

OPTIONS: Blowdown valve.

USE: Saturated and superheated steam.

AVAILABLE MODELS: BM20i – stainless steel.

SIZES: 1/2" to 1"; DN 15 to DN 25.

CONNECTIONS: Female threaded ISO 7 Rp or NPT.
Flanged EN 1092-1 PN 40.
Flanged ASME B16.5 Class 150 or 300.
Socket weld (SW) ASME 16.11.
Butt weld (BW) ASME B16.25 on request.

INSTALLATION: Inline horizontal installation is recommended.
See IMI – Installation and maintenance instructions.

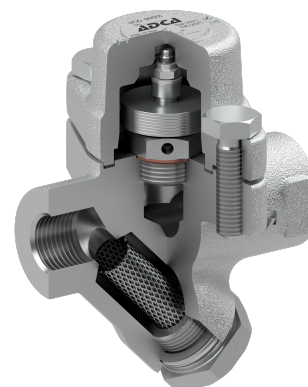
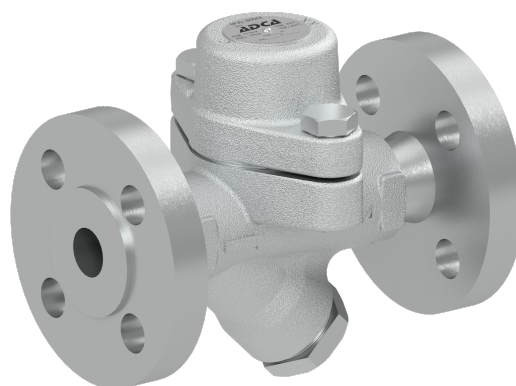

BODY LIMITING CONDITIONS			
FLANGED PN 40 *	FLANGED CLASS 150 **	FLANGED CLASS 300 **	RELAT. TEMP.
ALLOW. PRESSURE	ALLOW. PRESSURE	ALLOW. PRESSURE	
40 bar	15,3 bar	39,9 bar	50 °C
34,4 bar	12 bar	31,3 bar	150 °C
29,9 bar	10,2 bar	26,6 bar	250 °C
27,6 bar	9,7 bar	25,2 bar	300 °C

PMO – Max. operating pressure: 17 bar.

TMO – Max. operating temperature: 250 °C.

* Acc. to EN 1092-1:2018. ** Acc. to EN 1759-1:2004.

Body limiting conditions PN 40 or below, depending on the type of connection adopted. Rating PN 40 for threaded, SW and BW versions.

CE MARKING – GROUP 2 (PED – European Directive)

PN 40	Category
1/2" to 1" – DN 15 to 25	SEP

FLOW RATE CAPACITY (kg/h)

MODEL	SIZE	DIFFERENTIAL PRESSURE (bar)									
		0,5	1	2	4	6	8	10	12	14	17
BM20i	1/2" to 1" A DN 15 to 25 A	125	200	320	410	445	485	500	540	580	600
BM20i	1/2" to 1" B DN 15 to 25 B	450	700	1000	1220	1340	1450	1560	1650	1780	1850

A: Condensate discharge at 10 °C below saturation temperature; B: Cold water capacity around 20 °C.

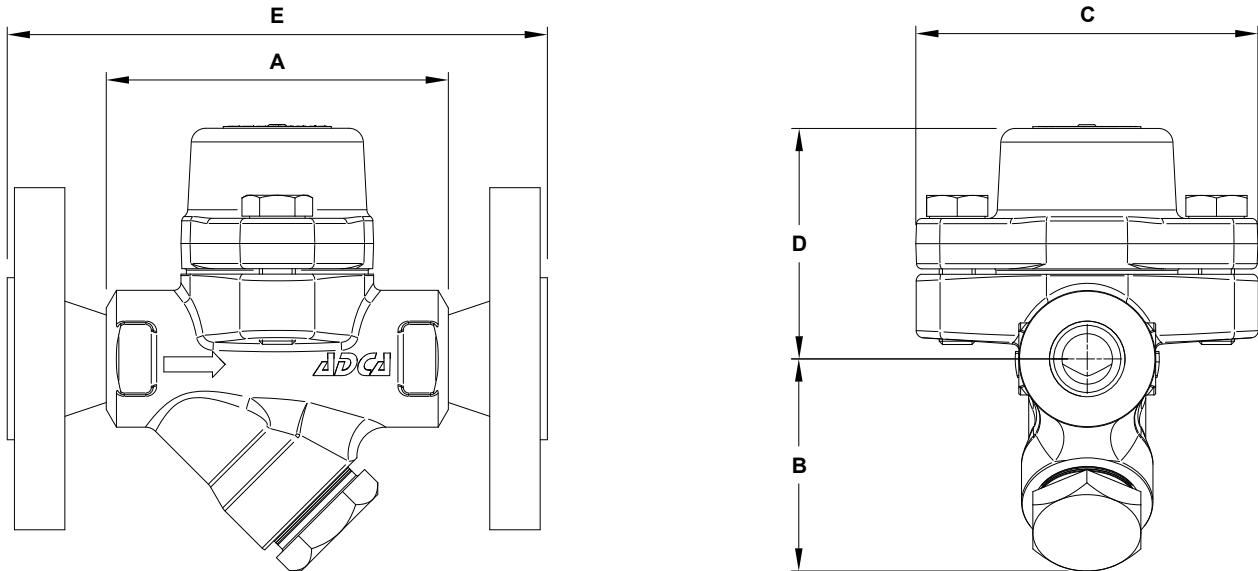

DIMENSIONS (mm)											
SIZE	THREADED / SW				PN 40		CLASS 150		CLASS 300		
	A	B	C	D	WEIGHT (kg)	E	WEIGHT (kg)	E	WEIGHT (kg)	E	WEIGHT (kg)
1/2" – DN 15	95	59	95	65	1,6	150	3,2	150	2,7	150	3,5
3/4" – DN 20	95	59	95	65	1,6	150	3,9	150	3,1	150	4,7
1" – DN 25	95	65	95	65	1,8	160	4,7	160	4,3	160	5,9

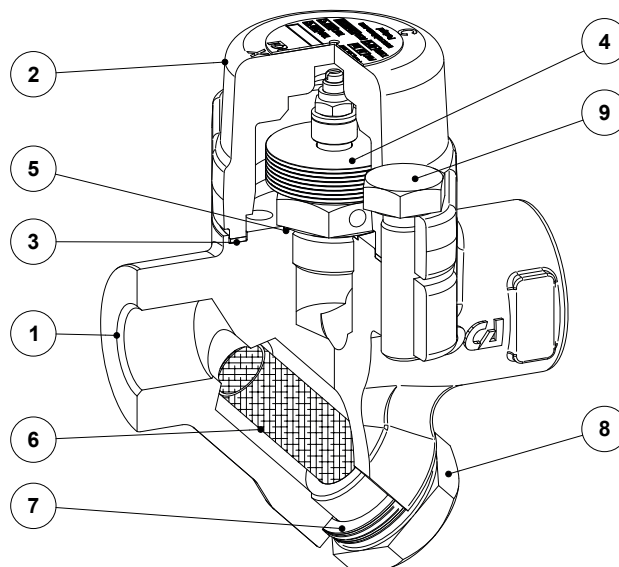

MATERIALS					
POS. N°	DESIGNATION	MATERIAL	POS. N°	DESIGNATION	MATERIAL
1	Body	AISI 316L / 1.4404	6	* Strainer screen	AISI 304 / 1.4301
2	Cover	AISI 316L / 1.4404	7	* Strainer gasket	Stainless steel / Graphite
3	* Gasket	Stainless steel / Graphite	8	* Strainer cover	AISI 303 / 1.4305
4	* Bimetallic regulator	Corrosion resistant bimetal; Stainless steel	9	Bolts	Stainless steel A2-70
5	* Seat gasket	Copper			

* Available spare parts.