

BIMETALLIC STEAM TRAPS AND AIR VENTS BM140

DESCRIPTION

The BM140 series bimetallic steam traps and air vents are simple and robust traps, recommended for steam process applications where condensate sensible heat can be recovered, steam tracing lines, drip points, storage tank coils, steam air venting, etc. The use of condensate sensible heat reduces steam consumption.

MAIN FEATURES

- Modulating discharge.
- Discharges condensate below steam temperature.
- Excellent air discharge.
- Operates on superheated steam.
- Unaffected by water hammer and vibrations.
- Built-in strainer.

USE: Saturated and superheated steam.

AVAILABLE

MODELS: BM140 – carbon steel.

SIZES: 1/2" to 1"; DN 15 to DN 25.

CONNECTIONS: Female threaded ISO 7 Rp or NPT.
Flanged EN 1092-1 PN 160.
Flanged ASME B16.5 Class 900.
Socket weld (SW) ASME B16.11.
Butt weld (BW) ASME B16.25.

INSTALLATION: Horizontal installation recommended, can be installed in any position.
See IMI – Installation and maintenance instructions.



CE MARKING – GROUP 2 (PED – European Directive)

PN 160	Category
1/2" to 1" – DN 15 to 25	SEP

BODY LIMITING CONDITIONS		
FLANGED PN 160 *	FLANGED CLASS 900 **	RELATED TEMP.
ALLOWABLE PRESSURE	ALLOWABLE PRESSURE	
160 bar	128,6 bar	300 °C
156 bar	120,7 bar	350 °C
141 bar	101,4 bar	450 °C
52 bar	46 bar	550 °C

Operating pressure: 25 to 140 bar.

* Acc. to EN 1092-1:2018. ** Acc. to EN 1759-1:2004.

Body limiting conditions PN 160 or below, depending on the type of connection adopted. Rating PN 160 for threaded, SW and BW versions.

FLOW RATE CAPACITY (kg/h)

MODEL	SIZE	DIFFERENTIAL PRESSURE (bar)									
		25	30	35	40	45	50	60	80	120	140
BM140	1/2" to 1" A DN 15 to 25 A	500	550	570	580	590	600	620	630	640	650
BM140	1/2" to 1" B DN 15 to 25 B	3000	3200	3600	4000	4200	4700	5400	6200	7800	8500

A: Condensate discharge at 10 °C below saturation temperature; B: Cold water capacity around 20 °C.

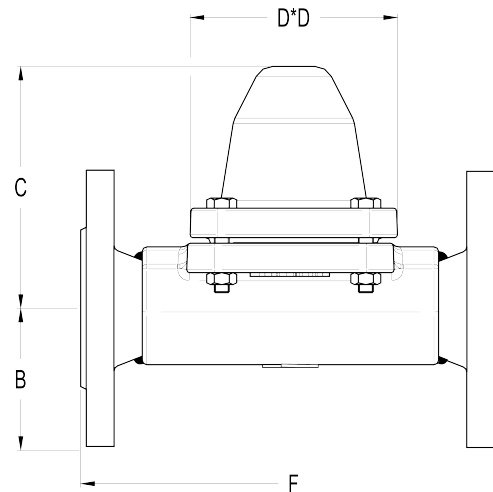
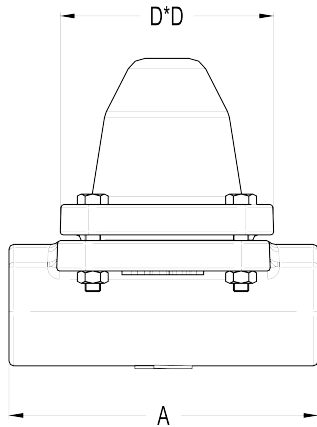

DIMENSIONS (mm)

SIZE	THREADED / SW / BW				PN 160			CLASS 900		
	A	C	D	WEIGHT (kg)	B	F *	WEIGHT (kg)	B	F *	WEIGHT (kg)
1/2" – DN 15	160	120	115	6,3	52,5	230	8,8	60	230	10,2
3/4" – DN 20	160	120	115	6,3	65	230	11,1	65	230	11,6
1" – DN 25	160	120	115	6,3	70	230	11,8	75	230	14

* Different face to face dimensions on request.

MATERIALS

POS. N°	DESIGNATION	MATERIAL
1	Body	A182F22 / 1.7380 (Equiv. 10CrMo910)
2	Cover	A182F22 / 1.7380 (Equiv. 10CrMo910)
3	* Gasket	Stainless steel / Graphite
4	* Valve assembly	Hardened stainless steel
5	* Strainer screen	AISI 304 / 1.4301
6	* Seat gasket	AISI 304 / 1.4301
7	Studs	A193 Gr. B7
7A	Nuts	A194 Gr. 2H

* Available spare parts.

