

FLOAT AND THERMOSTATIC STEAM TRAPS FLT80

DESCRIPTION

The FLT80 is a series of high capacity float and thermostatic steam traps with integral air vent, designed for modulating discharge of condensate to ensure maximum system heat transfer. Specially designed for applications where continuous drainage is essential and high loads are involved.

MAIN FEATURES

High capacity.
Modulating discharge of condensate at steam temperature.
Unaffected by sudden or wide load and pressure variations.
No backing-up with condensate.
Excellent air discharge through its integrated thermostatic air vent.

OPTIONS: Drain connection.
AFZ – Anti-freeze device.
BDV – Blowdown valve.

USE: Saturated and superheated steam.

AVAILABLE MODELS: FLT80S – carbon steel.

SIZES: 3" and 4"; DN 80 and DN 100.

CONNECTIONS: Flanged EN 1092-1 PN 16.
Flanged ASME B16.5 Class 150.

INSTALLATION: Angled horizontal installation.
See IMI – Installation and maintenance instructions.



CE MARKING – GROUP 2 (PED – European Directive)	
PN 16	Category
3" and 4" – DN 80 and 100	2 (CE marked)

BODY LIMITING CONDITIONS *	
FLANGED PN 16 / CLASS 150 ALLOW. PRESSURE	RELATED TEMPERATURE
14,8 bar	100 °C
13,3 bar	200 °C
12,1 bar	250 °C
11 bar	300 °C

PMO – Maximum operating pressure: 12 bar.
TMO – Maximum operating temperature: 250 °C.
Minimum operating temperature: -10 °C.
* According to EN 1092-1:2018.

FLOW RATE CAPACITY (kg/h)																	
MODEL	SIZE	DIFFERENTIAL PRESSURE (bar)															
		0,1	0,3	0,5	1	1,5	2	2,5	3	3,5	4	5	6	7	8	10	12
FLT80S	3" to 4" DN 80 to 100	37600	45400	49000	58000	62000	68000	74000	76000	79000	84000	87000	91000	94000	96000	99000	100000

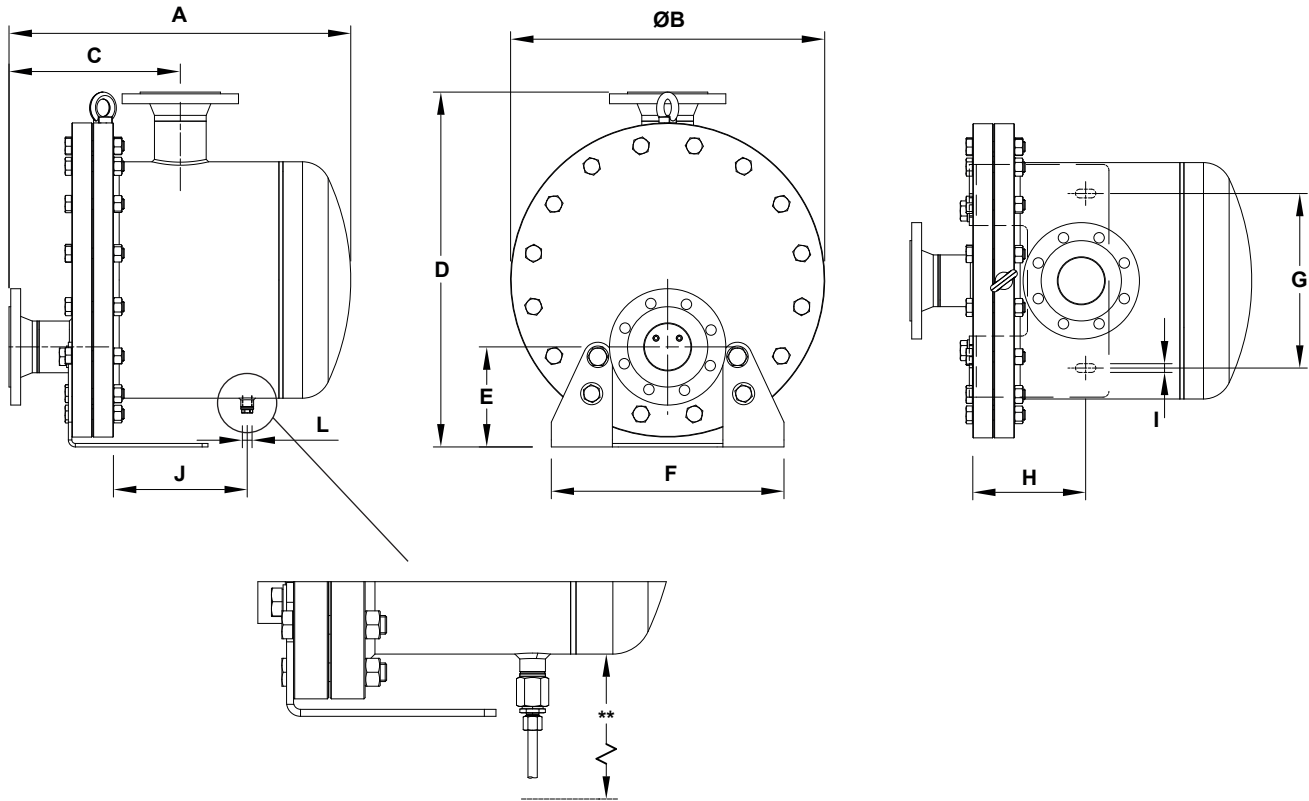

DIMENSIONS (mm)																
MODEL	SIZE	PN 16											Class 150		WGT. (kg)	
		A	ØB	C	D	E	F	G	H	I	J	L*	A	C		
FLT80S	3" – DN 80	587	540	294	610	172	400	300	194	15	230	3/8"	607	314	159	
FLT80S	4" – DN 100	634	540	341	610	172	400	300	194	15	240	3/8"	658	365	161	

* As standard, in versions with EN flanges, this connection is female threaded ISO 228. In versions with ASME flanges, this connection is female threaded NPT.

** In case an optional accessory is to be installed on the drain connection ensure there is enough clearance below the unit. A higher supporting frame can be supplied on request.

MATERIALS

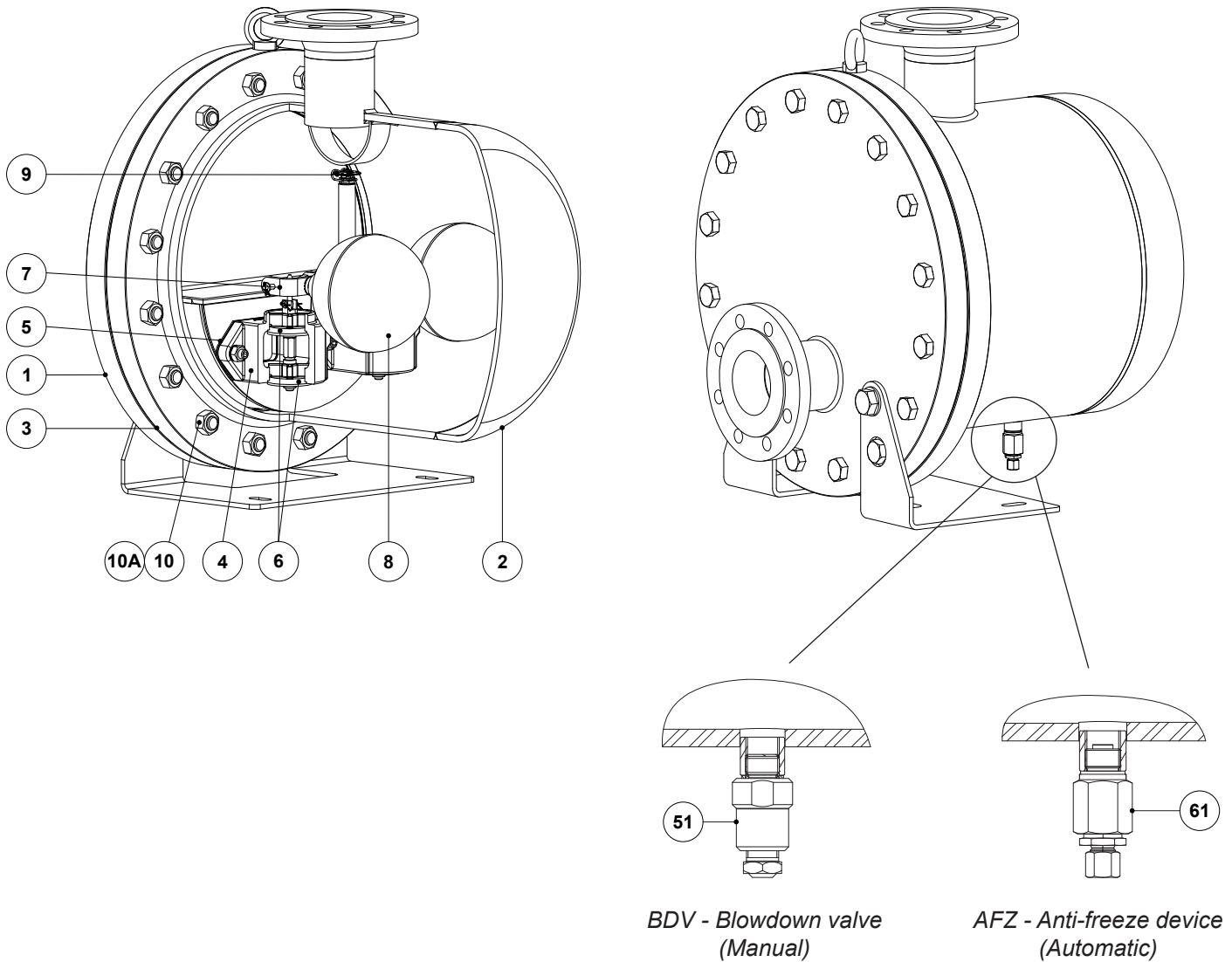

MATERIALS		
POS. N°	DESIGNATION	MATERIAL
1	Body	P235GH / 1.0345; P250GH / 1.0460; S235JR / 1.0038; S355J2 / 1.0577; A105 / 1.0432
2	Cover	P235GH / 1.0345; P250GH / 1.0460; P265GH / 1.0425; S355J2 / 1.0577; A105 / 1.0432
3	* Gasket	Stainless steel / Graphite
4	* Seat	CF8M / 1.4408
5	* Gasket	Stainless steel / Graphite
6	* Valve	CA-40 / 1.4027; AISI 410 / 1.4006
7	* Lever	AISI 316 / 1.4401; AISI 304 / 1.4301
8	* Float	AISI 304 / 1.4301
9	* Automatic air vent	Stainless steel (thermostatic)
10	Bolts	Steel 8.8
10A	Nuts	Steel 8.8
51	Blowdown valve	AISI 303 / 1.4305; AISI 316L / 1.4404
61	Anti-freeze device	AISI 303 / 1.4305; AISI 316L / 1.4404

* Available spare parts.