

## DIAPHRAGM SENSING PRESSURE REDUCING VALVE PRV30 (1 1/2" – 2"; DN 40 – DN 50)

### DESCRIPTION

The ADCA PRV30 series direct acting, spring-loaded diaphragm sensing, balanced plug pressure reducing valves, are designed for use with compressed air, water and other gases and liquids compatible with the materials of construction.

They are suitable for pressure reducing stations at the point of use on laundry machines, dyeing, food industries, sterilizers, etc.

### MAIN FEATURES

Compact design.  
Balanced valve plug.  
Machined from bar stock materials.

**OPTIONS:** Different soft valves for water and gases.  
Relieving – Internal relief valve to allow reduced outlet pressure in a no-flow condition.  
Built-in strainer.  
1/4" outlet gauge connection on body.  
Top cap (adjustment screw with cover).

**USE:** Compressed air, water and other gases and liquids compatible with the construction.

**AVAILABLE MODELS:** PRV30SS – stainless steel, diaphragm sensing.

**SIZES:** 1 1/2" and 2"; DN 40 and DN 50.

**CONNECTIONS:** Female threaded ISO 7 Rp or NPT.  
DN 40: Flanged EN 1092-1 Type 11 B PN 40 or PN 63.  
DN 50: Flanged EN 1092-1 Type 01 A PN 40 \*.  
DN 50: Flanged EN 1092-1 Type 11 B PN 63.  
\* Type 11 B PN 40 welding neck available, with different face to face dimensions.

**INSTALLATION:** Horizontal installation.  
A "Y" strainer should be installed upstream of the valve.  
See IMI – Installation and maintenance instructions.



Type 11 B flanges



Type 01 A flanges

FLOW RATE COEFFICIENTS (m³/h)		
SIZE	1 1/2" – DN 40	2" – DN 50
Kvs	12,7	13,7

LIMITING CONDITIONS	
Valve model	PRV30SS
Body design conditions	PN 63
Maximum upstream pressure	50 bar
Maximum downstream pressure	15 bar
Minimum downstream pressure	0,2 bar
Maximum design temperature *	80 °C
Maximum recommended reducing ratio	40:1

\* Others on request.

#### CE MARKING – GROUP 2 (PED – European Directive)

PN 63	Category
1 1/2" to 2" – DN 40 to 50	SEP

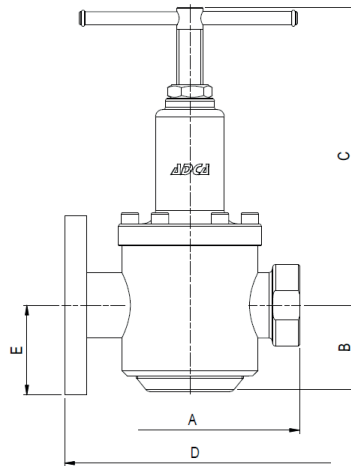

DIMENSIONS (mm)																		
THREADED				PN 40			PN 63/100			CLASS 150			CLASS 300					
SIZE	A	B	C	WGT. (kg)	D *	E	WGT. (kg)	D *	E PN 63	E PN 100	WGT. (kg)	D *	E	WGT. (kg)	D *	E	WGT. (kg)	
1 1/2" – DN 40	205	86	268	13	201	75	16,3	260	85	85	20,3	235	63,5	15,5	248	78	18	
2" – DN 50	205	80	274	13,3	230 **	82,5	18,5	300	90	97,5	22,8	254	76	18	267	82,5	20	

\* Different lenghts on request.

\*\* Only available with flat flanges EN 1092-1 type 01 A. Welding neck type 11 B flanges as option with 300 mm minimum face to face dimensions.

MATERIALS		
POS. N°	DESIGNATION	MATERIAL
1	Valve body	AISI 316 / 1.4401
2	Top cover	A351 CF8M / 1.4408
3	Seat cover	AISI 316 / 1.4401
4	* O-ring	NBR
5	* Piston valve	AISI 316 / 1.4401
6	* Valve head	NBR; EPDM; PTFE; etc.
6A	* Pushrod	AISI 316 / 1.4401
7	* O-ring	NBR; EPDM; PTFE; etc.
8	* Valve spring	AISI 302 / 1.4300
9	Pusher disc	AISI 304 / 1.4301
10	* Diaphragm	PTFE
11	* Diaphragm	NBR **
13	Spring plate	AISI 304 / 1.4301
14	Nut	Stainless steel A2-70
15	* Adjustment spring	Spring steel
16	Top spring plate	Brass
17	Adjustment screw	AISI 304 / 1.4301
18	Locknut	Stainless steel A2-70
20	Spring id. plate	Aluminium
21	Bolts	Stainless steel A2-70

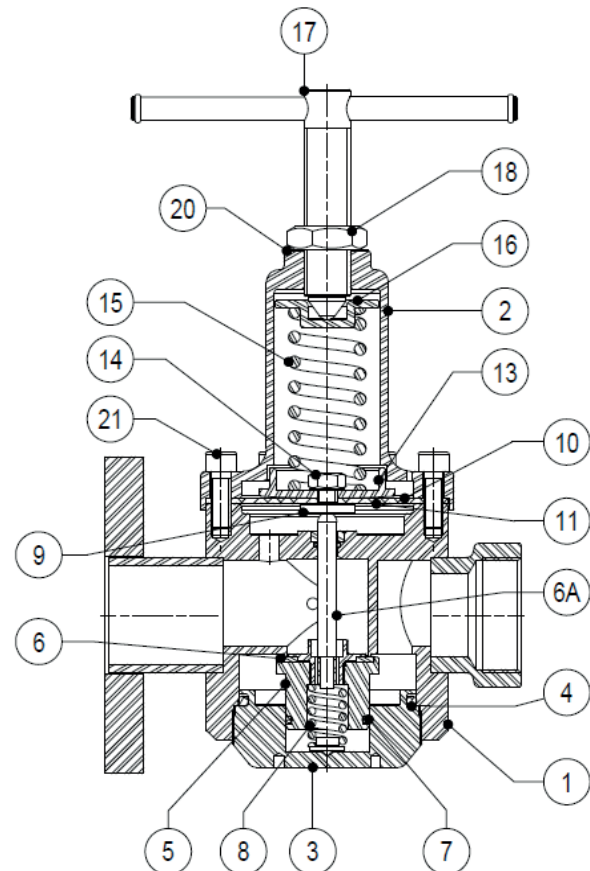

\* Available spare parts; \*\* Stainless steel on request.

Remarks: All valves have a serial number. In case of non-standard valves this number must be supplied if spare parts are ordered.

ORDERING CODES PRV30												
Valve model	R30	.	1	W	N	C	S	4	R	.	A	40
PRV30SS – diaphragm sensing pressure reducing valve	R30											
Regulating range												
N°1 – 0,2 to 1,5 bar			1									
N°2 – 0,3 to 3 bar			2									
N°3 – 0,8 to 8 bar			3									
N°4 – 1,5 to 15 bar			4									
Application												
Water				W								
Gases				G								
Oxygen (degreased)				O								
Seal material a)												
NBR					N							
EPDM					E							
PTFE					T							
FPM / Viton					V							
Maximum inlet pressure												
30 bar						C						
50 bar b)						D						
Diaphragm												
Stainless steel (non relieving)							S					
Rubber / PTFE (relieving or non-relieving)							R					
Gauge port 1/4"												
Without gauge ports								(1)				
Gauge port on the left side (relative to the flow direction)								4				
Gauge port on the right side (relative to the flow direction)								3				
Gauge ports on both sides								2				
Relieving												
Non-relieving									(1)			
Relieving (for non-dangerous gases only)									R			
Pipe connection												
Female threaded ISO 7 Rp											A	
Female threaded NPT ASME B1.20.1											C	
Socket weld (SW) ASME B16.11											H	
Butt weld (BW) ASME B16.25											I	
Flanged EN 1092-1 PN 40											N	
Flanged EN 1092-1 PN 63											O	
Flanged ASME B16.5 Class 150											U	
Flanged ASME B16.5 Class 300											V	
Flanged ASME B16.5 Class 600											W	
Size												
11/2" or DN 40												40
2" or DN 50												50
Special valves / Extras												
Full description or additional codes have to be added in case of non-standard combination.												E

(1) Omitted if a standard valve is requested.

a) Valve limited to the materials' maximum operating temperature. Consult manufacturer for more details.

b) The 50 bar inlet is available only with spring n° 4.