

DIAPHRAGM SENSING PRESSURE REDUCING VALVE PRV300 (1/2" – 3/4"; DN 15 – DN 20)

DESCRIPTION

The ADCA PRV300 series direct acting, spring-loaded diaphragm sensing, balanced plug pressure reducing valves, are designed for use with compressed air, water and other gases and liquids compatible with the materials of construction.

They are suitable for high accuracy pressure reducing stations at the point of use on laundry machines, dyeing, food industries, sterilizers, etc.

MAIN FEATURES

- Compact design.
- Large high accuracy diaphragm.
- Balanced valve plug.
- Machined from bar stock materials and investment casting.

- OPTIONS:**
- Different soft valves for water and gases.
 - Relieving – internal relief valve to allow reduced outlet pressure in a no-flow condition.
 - Built-in strainer.
 - 1/4" outlet gauge connection on body.
 - Top cap (adjustment screw with cover).

- USE:**
- Compressed air, water and other gases and liquids compatible with the construction.

- AVAILABLE MODELS:**
- PRV300SS – stainless steel, diaphragm sensing.

- SIZES:**
- 1/2" and 3/4"; DN 15 and DN 20.

- CONNECTIONS:**
- Female threaded ISO 7 Rp or NPT.
 - Flanged EN 1092-1 PN 16.
 - Flanged ASME B16.5 Class 150.

- INSTALLATION:**
- Horizontal installation.
 - A "Y" strainer should be installed upstream of the valve.
 - See IMI – Installation and maintenance instructions.



FLOW RATE COEFFICIENTS (m³/h)		
SIZE	1/2" – DN 15	3/4" – DN 20
Kvs	2,1	2,4

LIMITING CONDITIONS	
Valve model	PRV300
Body design conditions	PN 16
Maximum upstream pressure	16 bar
Maximum downstream pressure	0,7 bar
Minimum downstream pressure	0,05 bar
Maximum design temperature *	80 °C
Maximum recommended reducing ratio	40:1

* Others on request.

CE MARKING – GROUP 2 (PED – European Directive)	
PN 16	Category
1/2" to 3/4" – DN 15 to 20	SEP

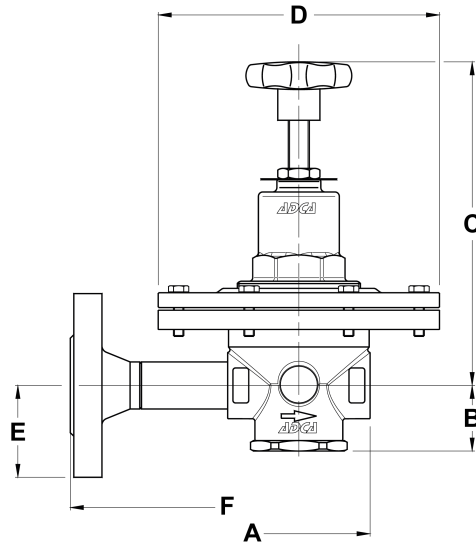

DIMENSIONS (mm)

SIZE	THREADED					PN 16		
	A	B	C	D	WEIGHT (kg)	E	F *	WEIGHT (kg)
1/2" – DN 15	80	38	185	160	3,9	47,5	260	5,3
3/4" – DN 20	80	38	185	160	3,9	52,5	260	5,9

* Different lengths on request.

MATERIALS

POS. N°	DESIGNATION	MATERIAL
1	Valve body	AISI 316 / 1.4401; A351 CF8M / 1.4408
2	Cover	AISI 316 / 1.4401
2A	Spring cover	AISI 316 / 1.4401; A351 CF8M / 1.4408
2B	Bolts	Stainless steel A2-70
3	Seat cover	AISI 316 / 1.4401
4	* O-ring	NBR
5	* Piston valve	AISI 316 / 1.4401
6	* Valve head	NBR
6A	* Pushrod	AISI 316 / 1.4401
7	* O-ring	NBR
8	* Valve spring	AISI 302 / 1.4300
8A	* Strainer screen	AISI 304 / 1.4301
9	Pusher disc	AISI 304 / 1.4301
10	* Diaphragm	Rubber
13	Spring plate	AISI 304 / 1.4301
14	Nut	Stainless steel A2-70
15	* Adjustment spring	Steel
16	Top spring plate	Brass
17	Adjustment screw	Steel
18	Locknut	Stainless steel A2-70
19	Handwheel	Plastic
20	Spring Id. plate	Aluminium

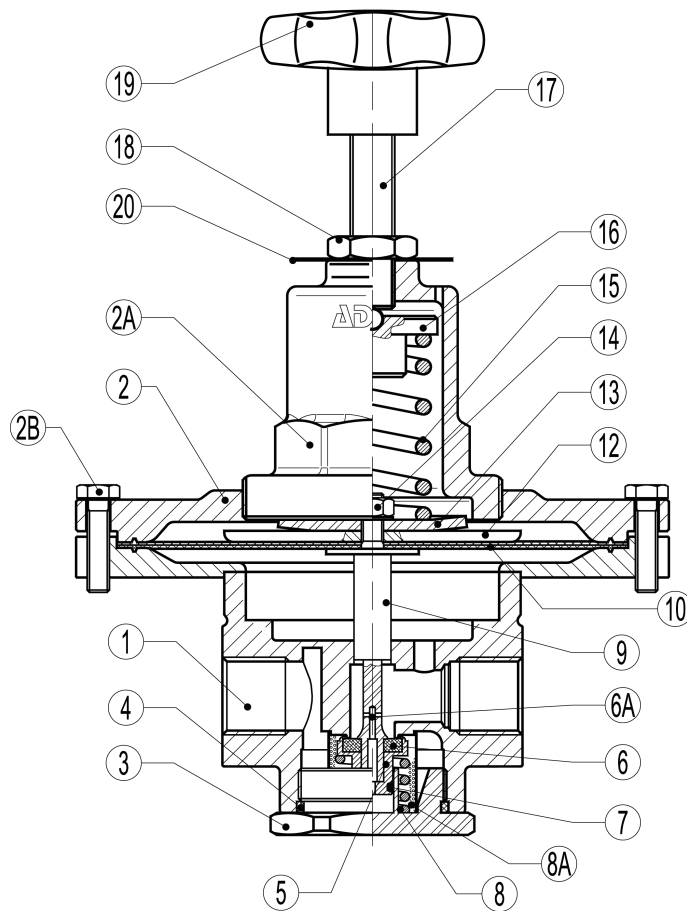

* Available spare parts.

Remarks: All valves have a serial number. In case of non-standard valves this number must be supplied if spare parts are ordered.

ORDERING CODES PRV300												
Valve model	R300	.	1	W	N	B	R	4	.	A	15	
PRV300SS – diaphragm sensing pressure reducing valve	R300											
Regulating range												
N° 1 – 0,05 to 0,7 bar			1									
Application												
Water				W								
Gases				G								
Oxygen (degreased)				O								
Seal material a)												
NBR					N							
EPDM					E							
PTFE					T							
FPM / Viton					V							
Maximum inlet pressure												
16 bar						B						
Diaphragm												
Rubber/PTFE (relieving or non-relieving)							R					
Gauge port 1/4"												
Without gauge ports											(1)	
Gauge port on the left side (relative to the flow direction)											4	
Gauge port on the right side (relative to the flow direction)											3	
Gauge ports on both sides											2	
Relieving												
Non-relieving											(1)	
Relieving (for non-dangerous gases only)											R	
Pipe connection												
Female threaded ISO 7 Rp												A
Female threaded NPT ASME B1.20.1												C
Socket weld (SW) ASME B16.11												H
Butt weld (BW) ASME B16.25												I
Flanged EN 1092-1 PN 40												N
Flanged EN 1092-1 PN 63												O
Flanged ASME B16.5 Class 150												U
Flanged ASME B16.5 Class 300												V
Flanged ASME B16.5 Class 600												W
Size												
1/2" or DN 15												15
3/4" or DN 20												20
Special valves / Extras												
Full description or additional codes have to be added in case of non-standard combination.												E

(1) Omitted if a standard valve is requested.

a) Valve limited to the materials maximum operating temperature. Contact manufacturer for more details.