

INVERTED BUCKET STEAM TRAPS IB35

DESCRIPTION

The IB35 series inverted bucket steam traps are recommended for applications where the most important requirements are overall operating efficiency and long, trouble-free service life.

They operate intermittently, either wide open or tightly closed and are, therefore, best suited for medium and high steam pressure applications.

MAIN FEATURES

- Intermittent discharge.
- Discharges condensate at steam temperature.
- Unaffected by water hammer and vibrations.
- Easy to maintain.

OPTIONS: Anti-freeze device.

USE: Saturated and superheated steam.

AVAILABLE MODELS: IB35S – carbon steel body, stainless steel cover.
 IB35SS – completely in stainless steel.

SIZES: 1/2" to 1"; DN 15 to DN 25.

CONNECTIONS: Female threaded ISO 7 Rp or NPT.
 Flanged EN 1092-1 PN 40.
 Flanged ASME B16.5 Class 150 or 300.
 Socket weld (SW) ASME 16.11.
 Butt weld (BW) ASME B16.25 on request.

INSTALLATION: Horizontal installation.
 See IMI – Installation and maintenance instructions.

MAX. ΔP: IB35S-17 – 17 bar
 IB35S-27 – 27 bar
 Remark: the same figures are valid for the IB35SS.



IB35S



IB35SS

CE MARKING – GROUP 2 (PED – European Directive)

PN 40	Category
1/2" to 1" – DN 15 to 25	SEP

FLOW RATE CAPACITY (kg/h)

MODEL	SIZE	DIFFERENTIAL PRESSURE (bar)																
		1	2	3	4	5	6	7	8	10	11	12	14	17	20	22	24	27
IB35S-17	1/2" to 1" DN 15 to 25	140	180	200	215	225	235	240	250	265	270	275	280	400	–	–	–	–
IB35S-27	1/2" to 1" DN 15 to 25	80	100	115	120	125	132	137	140	150	153	155	158	233	240	245	250	255

Remark: the same figures are valid for the IB35SS.

BODY LIMITING CONDITIONS					
IB35S		IB35SS			RELATED TEMPERATURE
FLANGED CLASS 150 **	FLANGED PN 40 / CLASS 300 *	FLANGED CLASS 150 **	FLANGED CLASS 300 **	FLANGED PN 40 *	
ALLOW. PRESS.	ALLOW. PRESS.	ALLOW. PRESS.	ALLOW. PRESS.	ALLOW. PRESS.	
17,7 bar	37,1 bar	13,3 bar	34,4 bar	37,9 bar	100 °C
14 bar	33,3 bar	11,1 bar	28,8 bar	31,8 bar	200 °C
8,4 bar	25,7 bar	8,4 bar	24,1 bar	26,4 bar	350 °C
6,5 bar	23,8 bar	6,5 bar	23,1 bar	25,7 bar	400 °C

PMO – Maximum operating pressure: 27 bar; TMO – Maximum operating temperature: 380 °C.

* According to EN 1092-1:2018; ** According to EN 1759-1:2004.

Body limiting conditions PN 40 or below, depending on the type of connection adopted. Rating PN 40 for threaded, SW and BW versions.

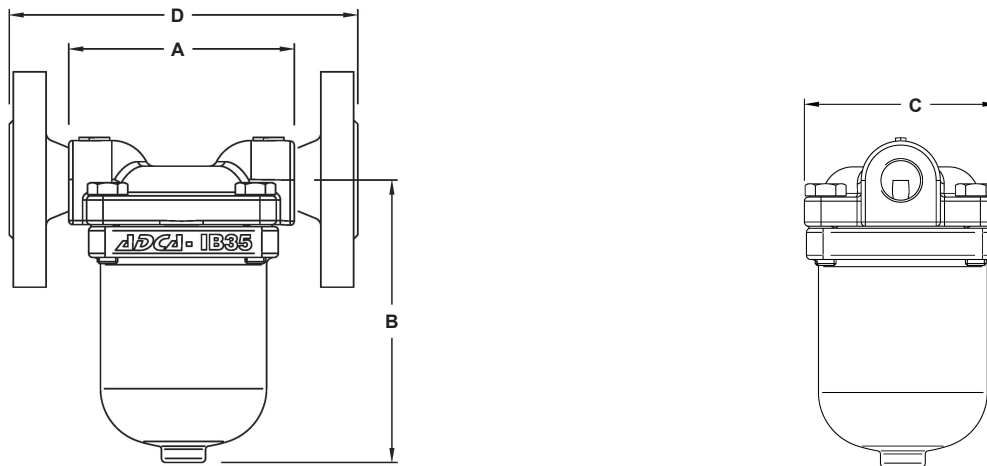

DIMENSIONS (mm)										
THREADED / SW				PN 40		CLASS 150		CLASS 300		
SIZE	A	B	C	WEIGHT (kg)	D	WEIGHT (kg)	D	WEIGHT (kg)	D	WEIGHT (kg)
1/2" – DN 15	110	125	92	2,3	170	3,8	170	3,3	170	4,1
3/4" – DN 20	110	125	92	2,3	170	4,3	170	3,7	170	5,3
1" – DN 25	110 / 160 *	125	92	2,3	180	4,9	180	4,5	180	6,5

* IB35SS is supplied with welded threaded socket.

MATERIALS		
POS. N°	DESIGNATION	MATERIAL
1	Body (IB35S)	P250GH / 1.0460
	Body (IB35SS)	A351 CF8M / 1.4408
2	Cover	A351 CF8M / 1.4408
3	* Gasket	Graphite
4	* Seat	AISI 410 / 1.4006
5	* Valve	AISI 410 / 1.4006
6	* Lever	AISI 304 / 1.4301
7	* Bucket	AISI 304 / 1.4301
8	Inlet tube	AISI 304 / 1.4301
9	Bolts	Stainless steel A2-70
10	** Anti-freeze device	AISI 304 / 1.4301

* Available spare parts; ** Optional.

