

PRESSURE REDUCING VALVE RP45 (Threaded)

DESCRIPTION

The ADCA RP45 series pressure reducing valves are single seated, bellows sealed controllers that operate without auxiliary energy. Designed for use with steam, compressed air, and other gases compatible with the construction. They are particularly suitable for reducing steam pressure in all energy and process systems where pressures must be kept under control.

MAIN FEATURES

Specially designed high durability bellows, providing pressure balancing and frictionless plug stem.
 Robust construction (fit-and-forget).
 Suitable for use with high pressure turndowns.
 Interchangeable actuators.

OPTIONS: Soft sealing version in PTFE/GR for use with steam.
 Nitrile rubber soft sealing version for air and gas applications, where tight shut-off is required.
 Low-noise flow divider.

USE: Steam, compressed air and other gases compatible with the construction. Limited use with liquids. Consult manufacturer before installing the valve with liquids.

AVAILABLE MODELS: RP45S and RP45ST or N – cast steel.
 RP45i and RP45iT or N – stainless steel.
 (All wetted parts free of ferrous metal or in stainless steel.)
 Suffix T: soft sealed with PTFE/GR.
 Suffix N: soft sealed with nitrile rubber.

SIZES: 1/2" to 1".

CONNECTIONS: Female threaded ISO 7 Rp or NPT.

AVAILABLE ACTUATORS: A1, A11, A12, A3, A4 – carbon steel.
 A2, A21 – SG iron or carbon steel.
 A1iS, A11i, A12i, A2i, A21i, A3i and A4i – stainless steel.

INSTALLATION: See IMI – Installation and maintenance instructions.



CE MARKING – GROUP 2 (PED – European Directive)	
PN 40	Category
1/2" to 1"	SEP

LIMITING CONDITIONS

Valve model	RP45S	RP45i	RP45ST	RP45iT	RP45SN	RP45iN
Body design conditions	PN 40	PN 40	PN 40	PN 40	PN 40	PN 40
Maximum upstream pressure	25 bar	25 bar	25 bar	25 bar	25 bar	25 bar
Maximum downstream pressure	13 bar	13 bar	13 bar	13 bar	13 bar	13 bar
Minimum downstream pressure	0,15 bar	0,15 bar	0,15 bar	0,15 bar	0,15 bar	0,15 bar
Maximum operating temperature	250 °C	250 °C	200 °C	200 °C	80 °C	80 °C
Maximum reducing ratio	25:1	25:1	25:1	25:1	10:1	10:1
Rangeability	10:1	10:1	10:1	10:1	10:1	10:1
Maximum hydraulic factory valve body test	60 bar	60 bar	60 bar	60 bar	60 bar	60 bar

Remarks: Other soft materials and temperature limits on request.

Actuator model	A1	A11	A12	A2	A21	A3	A4
Maximum operating pressure (bar)	25	25	25	12	18	2,5	1,5
Maximum operating temperature	90 °C *						

* The water seal pot must be installed in the sensing pipe when operating with steam or liquids at temperatures above 90 °C.

Remark: Values shown are independent of the actuator available materials.

FLOW RATE COEFFICIENTS (m³/h)

SIZE	1/2"	3/4"	1"
Kvs	4,8	6,9	9,1

SATURATED STEAM CAPACITY TABLE (kg/h)

INLET (barg)	SIZE		
	1/2"	3/4"	1"
0,5	51	68	90
0,75	63	84	112
1	75	100	133
1,5	100	133	175
2	126	170	230
2,5	150	200	260
3	175	240	310
4	220	290	390
5	260	350	480
6	330	440	580
7	400	520	700
8	450	600	800
9	500	670	880
10	560	750	980
12	680	900	1180
14	800	1050	1400
16	920	1230	1630
18	1040	1400	1860
20	1170	1540	2100
22	1330	1780	2350
24	1500	2000	2600
25	1600	2150	2800

ACTUATOR AND SPRING SELECTION TABLE

SIZE		ACTUATOR							
		A4 A4i	A3 A3i	A2 A2i	A21 A21i	A1 A1i	A11 A11i	A12 A12i	
1/2"	Spring range (bar)	0,15-0,49	0,5-0,99	1,0-1,6	1,7-3,8	3,9-5,5	5,6-8,2	8,3-13	10-18
	Spring N°	66	60	60	60	60	60	60	60.1
3/4"	Spring range (bar)	0,15-0,49	0,5-0,99	1,0-1,6	1,7-3,8	3,9-5,5	5,6-8,2	8,3-13	10-18
	Spring N°	66	60	60	60	60	60	60	60.1
1"	Spring range (bar)	0,15-0,49	0,5-0,99	1,0-1,6	1,7-3,8	3,9-5,5	5,6-8,2	8,3-13	10-18
	Spring N°	66	60	60	60	60	60	60	60.1

CORRECTION FACTORS

Pressure ratio:

The capacities given in the table above are applicable in scenarios where P2 < 0,7 P1.

In the remaining scenarios a correction factor must be applied:

PRESSURE RATIO * P2 / P1	CORRECTION FACTOR f
≥ 0,7	1,25
≥ 0,8	1,6
≥ 0,9	2,25

* Pressure ratio in bar abs (barg + 1)

Superheated steam:

When the medium is superheated steam, instead of saturated steam, a correction factor must also to be applied. The required mass flow must be multiplied by the following factor:

$$\frac{V_h}{V_s}$$

where V_h = specific volume of superheated steam, and V_s = specific volume of saturated steam.

HOW TO SIZE (USING STEAM TABLE)

Example:

Required saturated steam capacity: 300 kg/h; Upstream pressure: 7 bar; Required downstream pressure: 5 bar.

Solution:

First determine correction factor for pressure ratio: $(5+1) / (7+1) = 0.75 \rightarrow f=1.25$,

Then multiply the given capacity: $300 \times 1,25 = 375 \text{ kg/h}$

Afterwards, refer to the cell with the number “7” in the column “INLET” of the saturated steam capacity table. In that line, the values for selection of the pressure reducing valve size can be found. In this particular scenario, a value equal to or higher than 375 kg/h is required and any of the values in the line is higher than that. Therefore, the closest value should be preferred, leading to a 1/2” valve selection.

On the actuator and spring selection table, for a downstream pressure of 5 bar, the recommended actuator is the A21, and the regulating spring is the N° 60.

Remarks: Never size the valve according to the pipe diameter in which it has to be fitted, but according to the actual flow required. Pipe sizing must also respect the maximum recommended flow velocities, according to the medium.

HOW TO SIZE (USING Kvs)

Please consult formulas on IS PV10.00 E or consult manufacturer.

HOW TO ORDER

RP45S 1/2” valve complete with spring N° 60, A21 actuator, condensate vessel and copper sensing pipe.

INSTALLATION

Horizontal installation with the actuator vertically, pointing downwards.

Installation with the actuator pointing upwards is possible only when the medium temperature is below 90 °C.

The sensing pipe, if not fitted on the valve body, must be installed downstream of the valve at a minimum of 1 meter away or 15 pipe diameters.

In steam applications, a “Y” strainer, humidity separator and steam trap should be installed upstream of the valve.

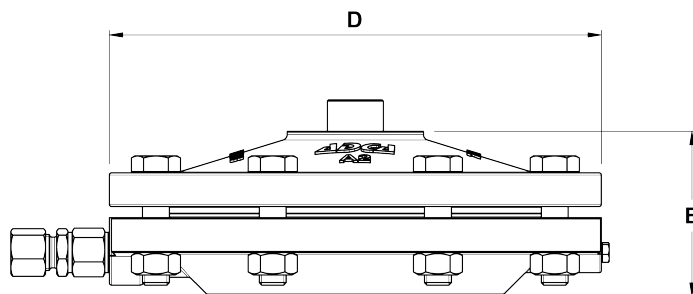
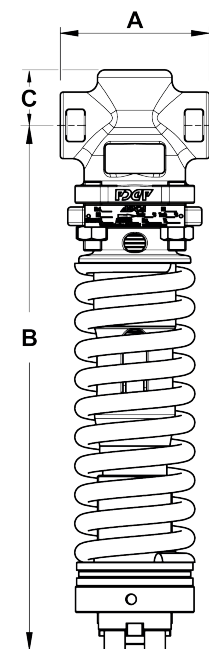

DIMENSIONS – VALVE (mm)			
DIMENSION	SIZE		
	1/2”	3/4”	1”
A	100	100	100
B	366	366	371
C	37,5	37,5	37,5
WEIGHT (kg)	1,2	11,5	12,1

DIMENSIONS – ACTUATOR (mm)							
DIMENSION	ACTUATOR						
	A1 A1i	A11 A11i	A12 A12i	A2 A2i	A21 A21i	A3 A3i	A4 A4i
D	172	172	172	220	220	282	340
E	67	67	67	74	74	71	81
WEIGHT (kg)	4,3	4,3	4,3	7,3	7,3	11,3	16,3

MATERIALS – VALVE

POS. N°	DESIGNATION	MATERIAL
1	Valve body (RP45S)	A216 WCB / 1.0619
	Valve body (RP45i)	A351 CF8M / 1.4408
2	Seat	AISI 316 / 4.4401
3	Stem	AISI 304 / 1.4301
4	* Valve plug	AISI 420 / 1.4021
6	Ball	AISI 440C / 1.4125
7	Stem guide	AISI 304 / 1.4301
8	Pin	AISI 301 / 1.4310
9	Compensating spring	AISI 302 / 1.4300
10	* Bellows	AISI 316Ti / 1.4571
11	Guide tube	CuZn39Pb3
12	Bellows gasket	Stainless steel / Graphite
13	Body gasket	Stainless steel / Graphite
14	O-ring	EPDM
15	Piston body	A216 WCB / 1.0619
16	Studs	34CrNiMo6 / 1.6582
17	Nuts	Zinc plated steel
18	Regulating spring	Spring steel
19	Threaded tube	CuZn39Pb3
20	Spring adjusting nut	C45E / 1.1191
21	Ball bearing	Zinc plated steel
22	Spacer	S355J2G3 / 1.0570
23	Pressure star	S235JR / 1.0038
24	Lock nut	C45E / 1.1191
25	Pressure tube	C45E / 1.1191
26	Pin	AISI 303 / 1.4305

* Available spare parts.

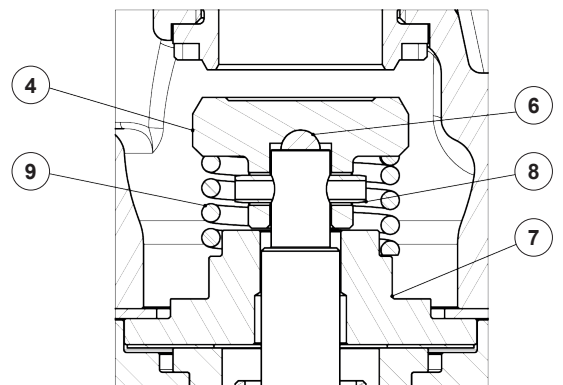
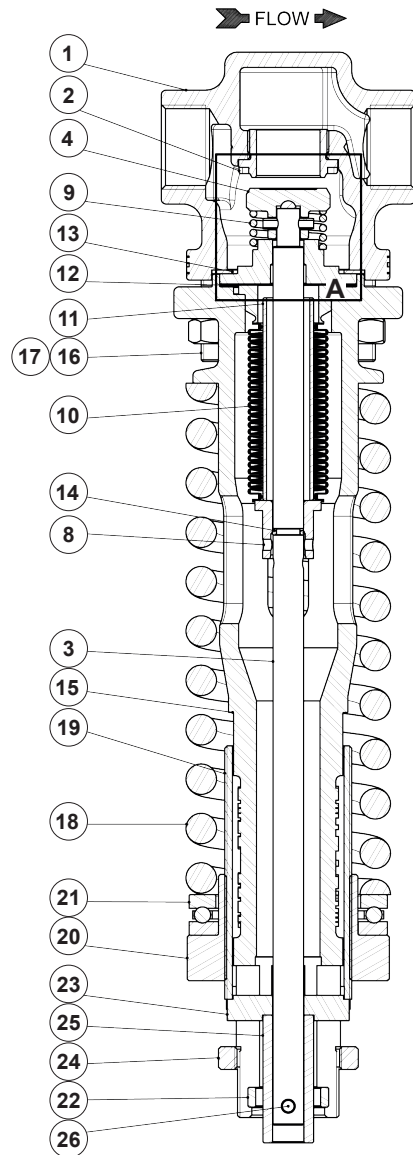

Detail A

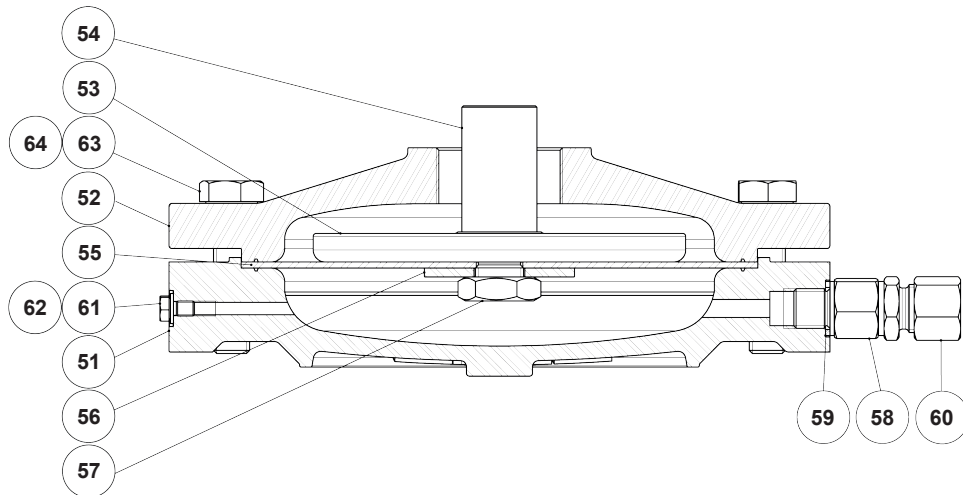

MATERIALS – ACTUATOR

POS. N°	DESIGNATION	A1 / A11 / A12 / A3 / A4	A2 / A21	A1i / A11i / A12i / A2i / A21i / A3i / A4i
51	Lower diaphragm chamber	A216 WCB / 1.0619	GJS-400-15 / 0.7040; A216 WCB / 1.0619	A351 CF8M / 1.4408
52	Upper diaphragm chamber	A216 WCB / 1.0619	GJS-400-15 / 0.7040; A216 WCB / 1.0619	A351 CF8M / 1.4408
53	Pressure plate	GJS-400-15 / 0.7040	GJS-400-15 / 0.7040	A351 CF8M / 1.4408; AISI 304 / 1.4301
54	Diaphragm plate spindle	GJS-400-15 / 0.7040	GJS-400-15 / 0.7040	A351 CF8M / 1.4408; AISI 304 / 1.4301
55	Diaphragm	Neoprene reinforced polyamid	Neoprene reinforced polyamid	Neoprene reinforced polyamid
56	Washer	Copper	Copper	AISI 304 / 1.4301
57	Hex nut	CuZn39Pb3	CuZn39Pb3	AISI 304 / 1.4301
58	Flow restrictor	AISI 303 / 1.4305	AISI 303 / 1.4305	AISI 303 / 1.4305
59	Gasket	Copper	Copper	Copper
60	Compression fitting	AISI 316Ti / 1.4571	AISI 316Ti / 1.4571	AISI 316Ti / 1.4571
61	Bolts	Zinc plated steel	Zinc plated steel	AISI 304 / 1.4301
62	Washer	Copper	Copper	AISI 304 / 1.4301
63	Bolts	Zinc plated steel	Zinc plated steel	AISI 304 / 1.4301
64	Nuts	Zinc plated steel	Zinc plated steel	AISI 304 / 1.4301