

FLOAT AND THERMOSTATIC STEAM TRAPS

FLT17

(11/2" – 2"; DN 40 – DN 50)

DESCRIPTION

The FLT17 float and thermostatic (integral air vent) steam traps series are designed for all types of low and high pressure steam heating and process equipment.

Typical applications include unit heaters, heat exchangers, driers, jacketed vessels and all the applications where continuous drainage is essential.

MAIN FEATURES

Modulating discharge.

Discharges condensate at steam temperature.

Unaffected by sudden or wide load and pressure changes.

Excellent air discharge (by thermostatic air vent).

OPTIONS: SLR – steam lock release.
Equalizing plug or vent connection.

USE: Saturated and superheated steam.

AVAILABLE MODELS: FLT17-4,5 , 10 and 14 – SG iron.

SIZES: 11/2" to 2"; DN 40 to DN 50.

CONNECTIONS: Female threaded ISO 7 Rp or NPT.
Flanged EN 1092-2 PN 16.
Flanged ASME B16.42 Class 150.

INSTALLATION: Standard horizontal installation – from right to left (R-L). See IMI – Installation and maintenance instructions.

On request: Horizontal installation with the flow from left to right (L-R) or vertical with the flow from top to bottom (V).

MAX. ΔP: FLT17-4,5 – 4,5 bar
FLT17-10 – 10 bar
FLT17-14 – 14 bar



CE MARKING – GROUP 2 (PED – European Directive)

PN 16	Category
11/2" to 2" – DN 40 to DN 50	SEP

BODY LIMITING CONDITIONS		
FLANGED PN 16 *	FLANGED CLASS 150 **	RELATED TEMP.
ALLOWABLE PRESSURE	ALLOWABLE PRESSURE	
16 bar	15,4 bar	100 °C
15,5 bar	14,6 bar	150 °C
14,7 bar	13,8 bar	200 °C
13,9 bar	12,1 bar	250 °C

PMO – Max. operating pressure 14 bar;

TMO – Max. operating temperature 198 °C.

* Acc. to EN 1092-2:2018; ** Acc. to EN 1759-1:2004.

Body limiting conditions PN 16 or below, depending on the type of connection adopted. Rating PN 16 for threaded version.

FLOW RATE CAPACITY (kg/h)

MODEL	SIZE	DIFFERENTIAL PRESSURE (bar)											
		0,1	0,3	0,5	0,7	1	1,5	2	4,5	7	10	12	14
FLT17-4,5	11/2" to 2" – DN 40 to 50	1050	1750	2400	2700	3400	3900	4500	7300	–	–	–	–
FLT17-10	11/2" to 2" – DN 40 to 50	650	1100	1500	1700	2000	2600	3000	4000	5400	6200	–	–
FLT17-14	11/2" to 2" – DN 40 to 50	430	720	950	1100	1300	1600	1800	2600	3250	3900	4210	4950

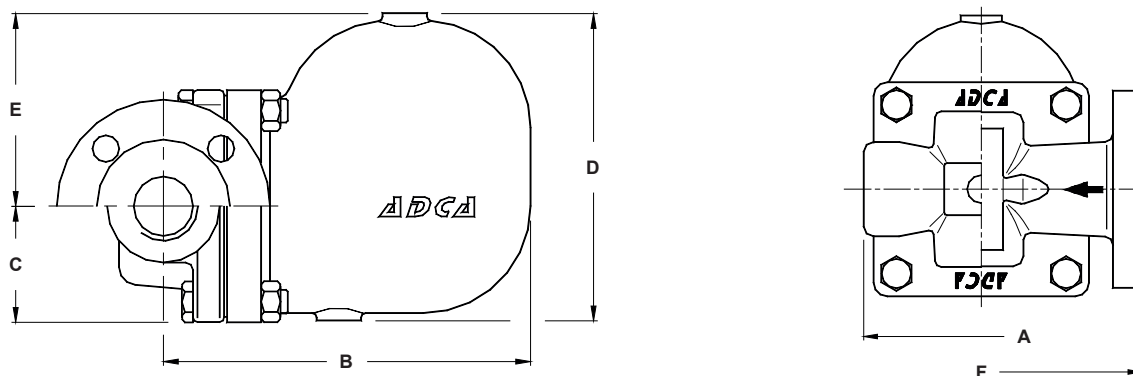

Horizontal Installation (R-L)

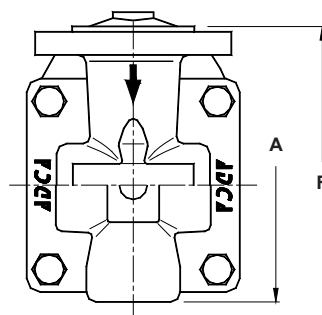

Vertical Installation (V)

DIMENSIONS (mm)												
THREADED							PN 16			CLASS 150		
SIZE	A	B	C	D	E	WEIGHT (kg)	F	B	WEIGHT (kg)	F	B	WEIGHT (kg)
1 1/2" – DN 40	210	248	79	208	131	16,9	230	248	20,3	230	248	19,1
2" – DN 50	210	248	79	208	131	17,5	230	248	20,7	230	248	20,5

MATERIALS		
POS. N°	DESIGNATION	MATERIAL
1	Body	GJS-400-15 / 0.7040
2	Cover	GJS-400-15 / 0.7040
3	* Gasket	Stainless steel / Graphite
4	* Seat	A351 CF8 / 1.4308
5	* Valve	AISI 420 / 1.4021
6	* Lever	AISI 304 / 1.4301
7	* Float	AISI 304 / 1.4301
8	* Air vent	Stainless st. (bimetallic)
9	Bolts	Steel 8.8

* Available spare parts.

