

FLOAT AND THERMOSTATIC STEAM TRAPS

FLT14I

(1/2" – 3/4"; DN 15 – DN 20)

DESCRIPTION

The FLT14I float and thermostatic (integral air vent) steam traps series are designed for all types of low and high pressure steam heating and process equipment.

Typical applications include unit heaters, heat exchangers, driers, jacketed vessels and all the applications where continuous drainage is essential.

MAIN FEATURES

- Modulating discharge.
- Discharges condensate at steam temperature.
- Unaffected by sudden or wide load and pressure changes.
- Excellent air discharge (by thermostatic air vent).

OPTIONS: SLR – steam lock release.
Equalizing plug or vent connection.

USE: Saturated and superheated steam.

AVAILABLE

MODELS: FLT14I-4,5 , 10 and 14 – stainless steel.

SIZES: 1/2" to 3/4"; DN 15 to DN 20.

CONNECTIONS: Female threaded ISO 7 Rp or NPT.
Flanged EN 1092-1 PN 16.
Flanged ASME B16.5 Class 150.
Socket weld (SW) ASME 16.11.
Butt weld (BW) ASME B16.25 on request.

INSTALLATION: Standard horizontal installation – from right to left (R-L). See IMI.
On request: Horizontal installation with the flow from left to right (L-R) or vertical with the flow from top to bottom (V).

MAX. ΔP: FLT14I-4,5 – 4,5 bar
FLT14I-10 – 10 bar
FLT14I-14 – 14 bar

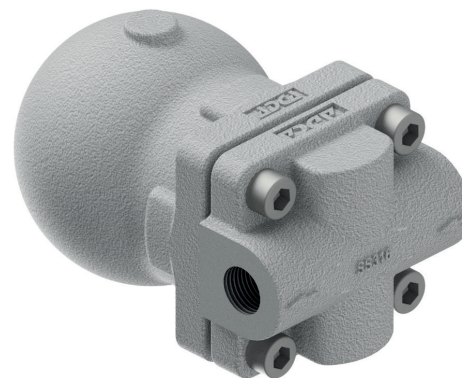

CE MARKING – GROUP 2 (PED – European Directive)

PN 16	Category
1/2" to 3/4" – DN 15 to DN 20	SEP

BODY LIMITING CONDITIONS		
FLANGED PN 16 *	FLANGED CLASS 150 **	RELATED TEMP.
ALLOWABLE PRESSURE	ALLOWABLE PRESSURE	
15,1 bar	13,3 bar	100 °C
13,7 bar	12 bar	150 °C
12,7 bar	11,1 bar	200 °C
11,9 bar	10,2 bar	250 °C

PMO – Maximum operating pressure 14 bar;
TMO – Maximum operating temperature 198 °C.
* Acc. to EN 1092-1:2018; ** Acc. to EN 1759-1:2004.
Body limiting conditions PN 16 or below, depending on the type of connection adopted. Rating PN 16 for threaded, SW and BW versions.

FLOW RATE CAPACITY (kg/h)

MODEL	SIZE	DIFFERENTIAL PRESSURE (bar)												
		0,5	1	1,5	2	3	4,5	6	7	8	9	10	12	14
FLT14I-4,5	1/2" to 3/4" DN 15 to 20	200	280	320	360	400	495	–	–	–	–	–	–	–
FLT14I-10	1/2" to 3/4" DN 15 to 20	110	140	175	190	230	280	300	330	350	390	405	–	–
FLT14I-14	1/2" to 3/4" DN 15 to 20	70	100	120	140	155	190	210	220	225	230	260	280	300

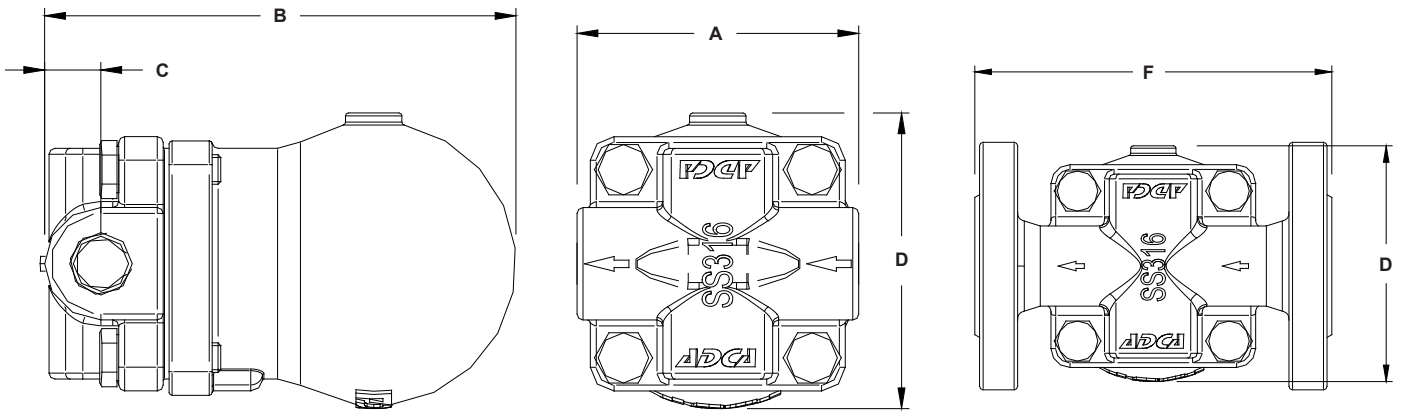

Horizontal Installation (R-L)

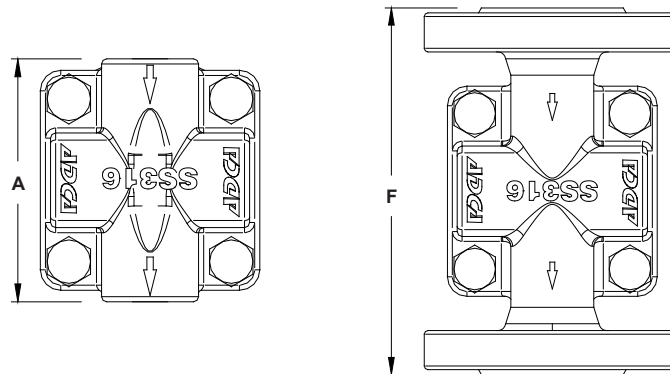

Vertical Installation (V)

DIMENSIONS (mm)									
SIZE	THREADED / SW				WEIGHT (kg)	PN 16		CLASS 150	
	A	B	C	D		F	WEIGHT (kg)	F	WEIGHT (kg)
1/2" – DN 15	95	160	23	100	3,5	150	5	150	4,5
3/4" – DN 20	95	160	23	100	3,5	150	5,5	150	4,7

MATERIALS		
POS. N°	DESIGNATION	MATERIAL
1	Body	A351 CF8M / 1.4408; AISI 316L / 1.4404
2	Cover	A351 CF8M / 1.4408
3	* Gasket	Stainless steel / Graphite
4	* Seat	AISI 410 / 1.4006
5	* Valve	AISI 440C / 1.4125
6	* Lever	AISI 304 / 1.4301
7	* Float	AISI 304 / 1.4301
8	* Air vent	Stainless st. (bimetallic)
9	Bolts	Stainless steel A2-70

* Available spare parts.

