

BELLOWS SEALED STOP VALVES VF20

DESCRIPTION

The VF20 is a series of maintenance free inline stop valves designed with double wall bellow sealing, secondary safety packing and non-rising handwheel. They are specially recommended for steam, gas, liquid, condensate, thermal oil and water applications.

MAIN FEATURES

Maintenance free design.
High durability sealing via double wall bellows.
Secondary safety packing.
Non-rising handwheel.
External stem thread.

OPTIONS: Parabolic plug for throttling applications.
PTFE soft sealing for applications up to 180 °C.

USE: Group 2 fluids compatible with the construction.

AVAILABLE MODELS: VF20 – cast iron.

SIZES: DN 15 to DN 200.

CONNECTIONS: Flanged EN 1092-2 PN 16.

INSTALLATION: See IMI – Installation and maintenance instructions.



CE MARKING – GROUP 2 (PED – European Directive)	
PN 16	Category
DN 15 to 50	SEP
DN 65 to 200	1 (CE marked)

BODY LIMITING CONDITIONS *	
ALLOWABLE PRESSURE	RELATED TEMPERATURE
16 bar	-10 °C / 120 °C
12,8 bar	200 °C
11,2 bar	250 °C
9,6 bar	300 °C

* Warning: The eventual use with steam/gas should be analyzed in accordance with the local applicable legislation, and always ensuring that there is no risk of water hammer.

FLOW RATE COEFFICIENTS (m³/h)												
SIZE	DN 15	DN 20	DN 25	DN 32	DN 40	DN 50	DN 65	DN 80	DN 100	DN 125	DN 150	DN 200
Kvs	5,9	7,4	13	18	30	41	79	115	181	225	364	725

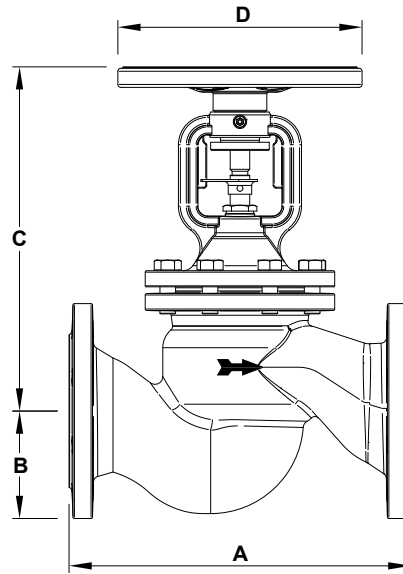

DIMENSIONS (mm)					
SIZE	A	B	C	D	WEIGHT (kg)
DN 15	130	47,5	178	125	3,2
DN 20	150	52,5	178	125	3,9
DN 25	160	57,5	193	125	4,6
DN 32	180	70	201	125	6,5
DN 40	200	75	224	150	9
DN 50	230	82,5	228	150	11
DN 65	290	92,5	270	175	15,8
DN 80	310	100	295	200	20,5
DN 100	350	110	352	250	35
DN 125	400	125	380	300	49
DN 150	480	142,5	427	400	76
DN 200	600	170	569	500	130,5

MATERIALS		
POS. N°	DESIGNATION	MATERIAL
1	Body	EN-GJL-250
2	Seat	Stainless steel
3	* Spindle	Stainless steel
4	* Disc	Stainless steel
5	Bonnet	EN-GJS-400-18-LT
6	* Bellows	Stainless steel
7	* Gasket	Stainless steel / Graphite
8	* Packing	Carbo-graphite
9	Gland	Zinc plated steel
10	Anti-friction disc	Zinc plated steel
11	Handwheel	Steel
12	Bolts	Steel 8.8

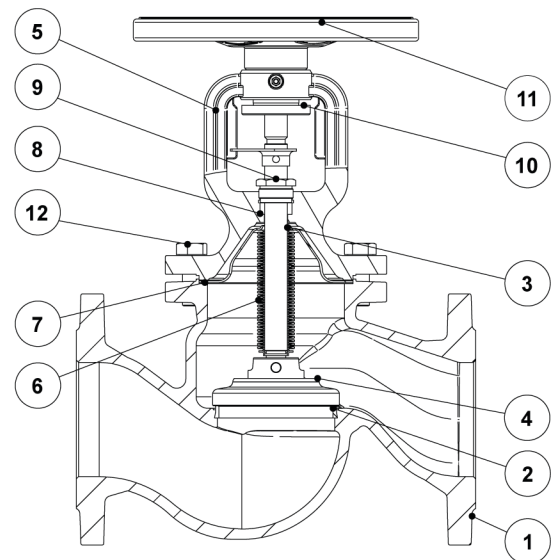

* Available spare parts.