

## SANITARY CHECK VALVES SRT10

### DESCRIPTION

The ADCAPure SRT10 all stainless steel disc check valve has a compact design and is specially designed for use with clean steam, hot condensate, WFI and other process fluids.

These valves are particularly recommended for use in high purity applications found in the pharmaceutical, fine chemical and cosmetic industries.

### MAIN FEATURES

Compact design.  
Spring loaded.  
Low friction stem guiding.  
Completely machined from bar stock material, no castings or forgings are used on the standard version.

### STANDARD SURFACE FINISH

Internal wetted parts:  $\leq 0,51 \mu\text{m Ra} - \text{SF1}$ .  
External:  $\leq 0,76 \mu\text{m Ra} - \text{SF3}$ .  
Other surface conditions see TIS.GIA – General information ADCAPure.  
Ultrasonic cleaning.

USE: Clean steam, water and other liquids and gases compatible with the construction.

AVAILABLE MODELS: SRTV10 – vertical installation.  
SRTH10 – horizontal installation.

SIZES: 1/2" to 4".

CONNECTIONS: ASME BPE clamp ferrules or tube weld (ETO) ends.  
Others on request.

PACKAGING: Assembling and packaging in a clean room certified according to ISO 14644-1.  
The product is end capped and sealed with recyclable thermo-shrinkable plastic film, to avoid contamination.

INSTALLATION: Vertical or horizontal according to the selected model and use.  
See IMI – Installation and maintenance instructions.



#### CE MARKING – GROUP 2 (PED – European Directive)

PN 10	Category
1/2" to 4"	SEP

#### LIMITING CONDITIONS \*

Maximum operating pressure	10 bar
Maximum operating temperature – EPDM seals	150 °C
Maximum operating temperature – EPDM seals (steam and water) **	180 °C
Maximum operating temperature – PTFE seals	200 °C
Minimum operating temperature	-10 °C

\* Other limits on request. Maximum operating conditions may be limited by the valve end connections due to normative restrictions.

\*\* High performance EPDM. Maximum operating temperature of 210 °C, for short periods of time.

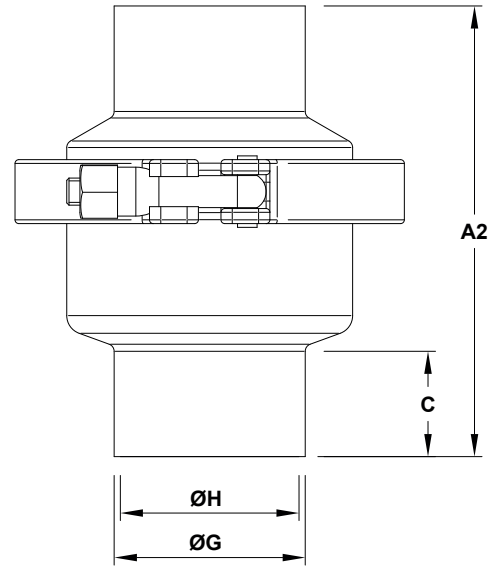
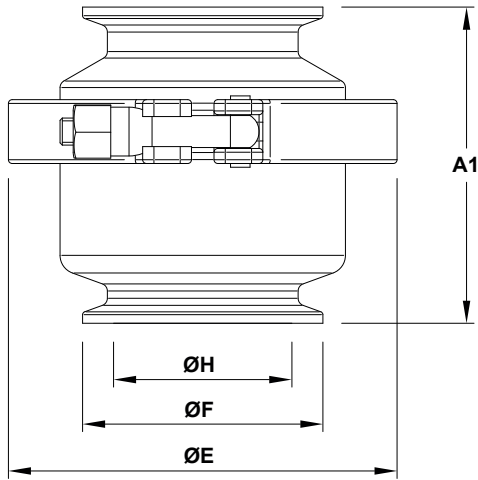

SRTV10

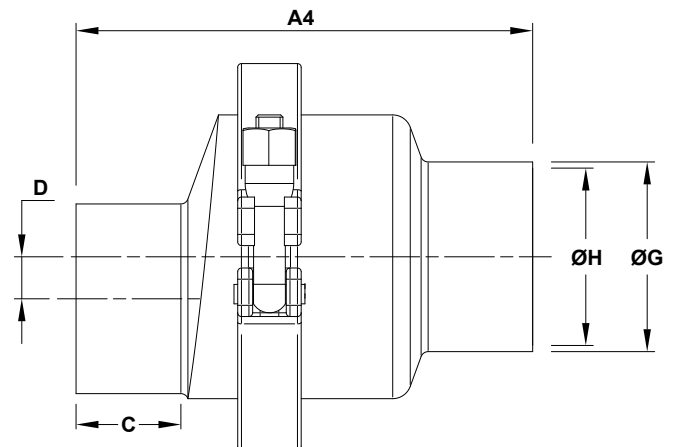
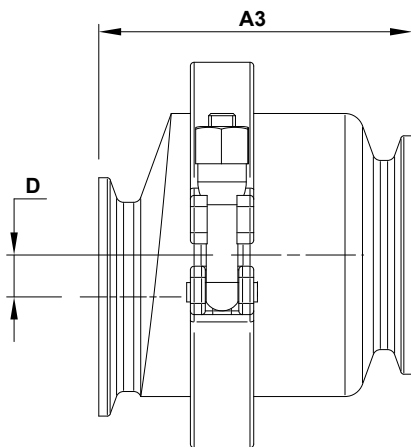

SRTH10

DIMENSIONS (mm)											
SIZE	A1	A2	A3	A4	C	D	ØE	F	ØG	ØH	WEIGHT (kg)
1/2"	50	88,8	50	90,4	28	11,8	61	25	12,7	9,4	0,4
3/4"	50	91,9	50	91,1	28	8,6	61	25	19,1	15,8	0,5
1"	60	97	60	96,5	28	5,5	61	50,4	25,4	22,1	0,6
1 1/2"	73	112,2	73	112,1	28	11,1	90	50,4	38,1	34,8	1,1
2"	84	119,8	84	122,3	28	11,3	104	63,9	50,8	47,5	1,4
2 1/2"	89	129	89	124	28	9,2	119	77,4	63,5	60,2	1,8
3"	98	141	98	134	28	11,1	134	90,9	76,2	72,9	2,7
4"	109	165,7	109	160	36	15,6	170	118,9	101,6	97,38	4,9

Remarks: Face to face dimensions are not standardized. Different dimensions available on request.

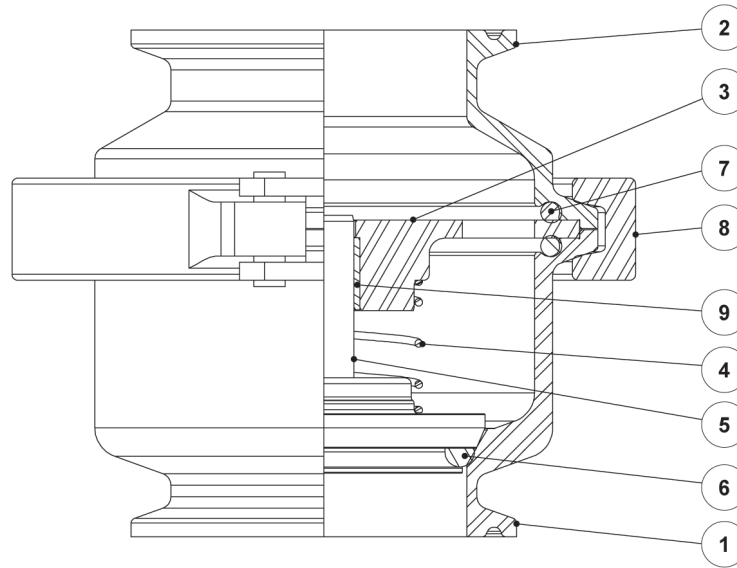

MATERIALS		
POS. N°	DESIGNATION	MATERIAL
1	Valve inlet body	AISI 316L / 1.4404
2	Valve outlet body	AISI 316L / 1.4404
3	Guide plate	AISI 316L / 1.4404
4	Spring	AISI 316 / 1.4401 electropolished
5	* Valve and stem	AISI 316L / 1.4404
6	* Valve seal	** High performance EPDM; PTFE
7	* Body seals	** High performance EPDM; PTFE
8	Safety clamp	AISI 316 / 1.4401
9	Plain bearing	** PTFE

\* Available spare parts. \*\* Others on request.

Remarks: FDA / USP Class VI seals certificate on request.

All valves have a serial number. In case of non-standard valves, this number must be supplied if spare parts are ordered.