

## SANITARY PRESSURE SUSTAINING VALVE PS160

### DESCRIPTION

The ADCA PS160 series direct acting, spring-loaded, diaphragm sensing pressure sustaining valves are designed for use with clean steam, compressed air, water and other gases or liquids compatible with the construction materials.

### MAIN FEATURES

Compact design.  
Completely machined from bar stock material, no castings or forgings are used on the standard version.  
Non-rising adjustment knob.

### STANDARD SURFACE FINISH

Internal wetted parts:  $\leq 0,51$  micron Ra – SF1.  
External:  $\leq 0,76$  micron Ra – SF3.  
Other surface conditions see IS PV20.00 E – Technical information.  
Ultrasonic cleaning.

**OPTIONS:** Leakage line connection 1/8" (captured vent).  
Different soft valves for liquids and gases.  
Gauge connection on body.  
Top cap (adjustment screw with cover).

**USE:** Clean steam, compressed air, water and other gases and liquids compatible with the construction.

**AVAILABLE MODELS:** PS160.

**SIZES:** 3/4" to 2"; DN 20 to DN 50.

**REGULATING RANGES:** 0,8 – 1,5 bar; 1 – 3 bar; 1,5 – 8 bar.

**CONNECTIONS:** ASME BPE, DIN and ISO clamp ferrules.  
Others on request.

**PACKAGING:** Assembling and packaging in a clean room certified according to ISO 14644-1.  
The product is end capped and sealed with recyclable thermo-shrinkable plastic film, to avoid contamination.

**INSTALLATION:** Horizontal installation. Horizontal inlet and vertical outlet angle connection.  
See IMI – Installation and maintenance instructions.

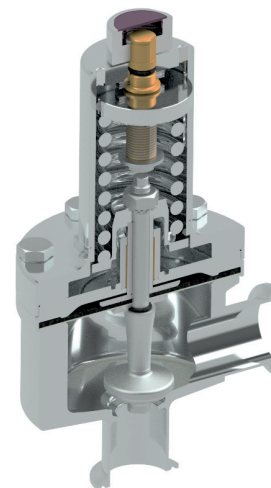

LIMITING CONDITIONS	
<b>Valve model</b>	<b>PS160</b>
Body design conditions	PN 16
Maximum upstream pressure	8 bar
Minimum upstream pressure	0,8 bar
Maximum design temperature *	150 °C

\* Others on request.

CE MARKING – GROUP 2 (PED – European Directive)	
PN 16	Category
3/4" to 2" – DN 20 to 50	SEP

FLOW RATE COEFFICIENTS (m³/h)

SIZE	BPE				DIN				ISO		
	3/4"	1"	1 1/2"	2"	DN 20	DN 25	DN 40	DN 50	DN 20	DN 25	DN 40
Kvs	1,3	3,5	5,5	8,5	1,3	3,5	5,5	8,5	1,3	3,5	5,5

DIMENSIONS (mm) ASME BPE

SIZE	A	B	C	D	d1	d2	E	F	H	WEIGHT (kg)
3/4"	85	56	192	130	25	15,75	89	25	15,75	6,7
1"	85	55	192	130	25	15,75	89	50,5	22,1	6,8
1 1/2"	85	65	199	130	25	15,75	89	50,5	34,8	7,6
2"	85	69	205	130	25	15,75	89	64	47,5	7,8

DIMENSIONS (mm) DIN

SIZE	A	B	C	D	d1	d2	E	F	H	WEIGHT (kg)
DN 20	89	62	192	130	25	15,75	89	34	20	6,6
DN 25	92	64	192	130	25	15,75	89	50,5	26	6,5
DN 40	92	75	199	130	25	15,75	89	50,5	38	7,2
DN 50	92	75	205	130	25	15,75	89	64	50	7,6

DIMENSIONS (mm) ISO

SIZE	A	B	C	D	d1	d2	E	F	H	WEIGHT (kg)
DN 20	81	49	192	130	25	15,75	89	50,5	23,7	6,5
DN 25	81	51	192	130	25	15,75	89	50,5	29,7	6,4
DN 40	92	80	199	130	25	15,75	89	64	44,3	7,7

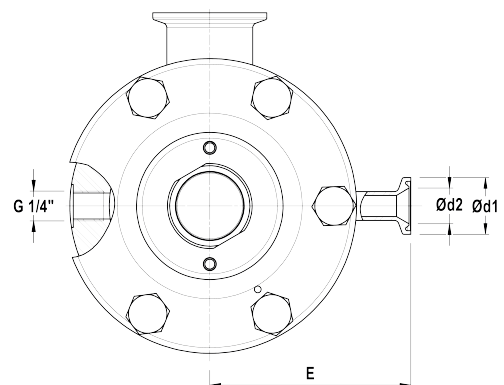
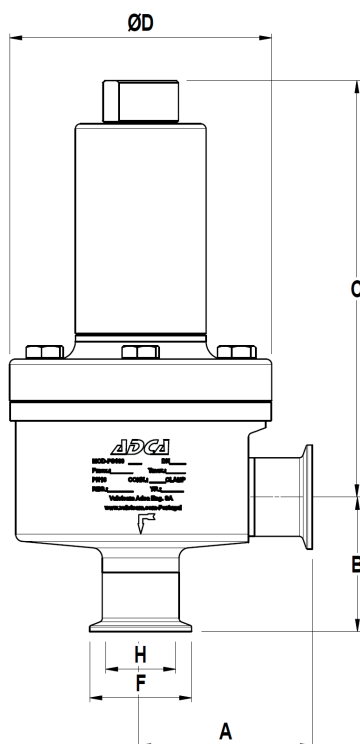

Optional pressure gauge connections.

**MATERIALS**

POS. N°	DESIGNATION	MATERIAL
1	Body	AISI 316L / 1.4404
2	Cover	AISI 316L / 1.4404
3	Centering plate	AISI 316L / 1.4404
3A	*** O-ring	EPDM
4	* Valve stem	AISI 316L / 1.4404
5	* Soft plug	** EPDM; PTFE
6	* Valve plug	AISI 316L / 1.4404
7	* Upper diaphragm	EPDM
8	* Lower diaphragm	PTFE (Gylon)
9	Diaphragm plate	AISI 316L / 1.4404
10	* O-ring	EPDM
11	Diaphragm plate	AISI 316L / 1.4404
12	Stem guide	AISI 316 / 1.4401
12A	Plain bearing	Bronze
13	Spring plate	AISI 316 / 1.4401
14	Nut	Stainless steel A2-70
15	Washer	AISI 316 / 1.4401
16	* Adjustment spring	AISI 302 / 1.4300
17	Top spring plate	AISI 316 / 1.4401
18	Retaining washer	Stainless steel A2-70
19	Adjustment nut	AISI 316L / 1.4404
20	Adjustment screw	Brass
21	O-ring	NBR
22	Bearing	Corrosion resistant steel
23	Ext. bowed shaft ring	Stainless steel
24	Nut cover	Plastic
25	Bolts	Stainless steel A2-70

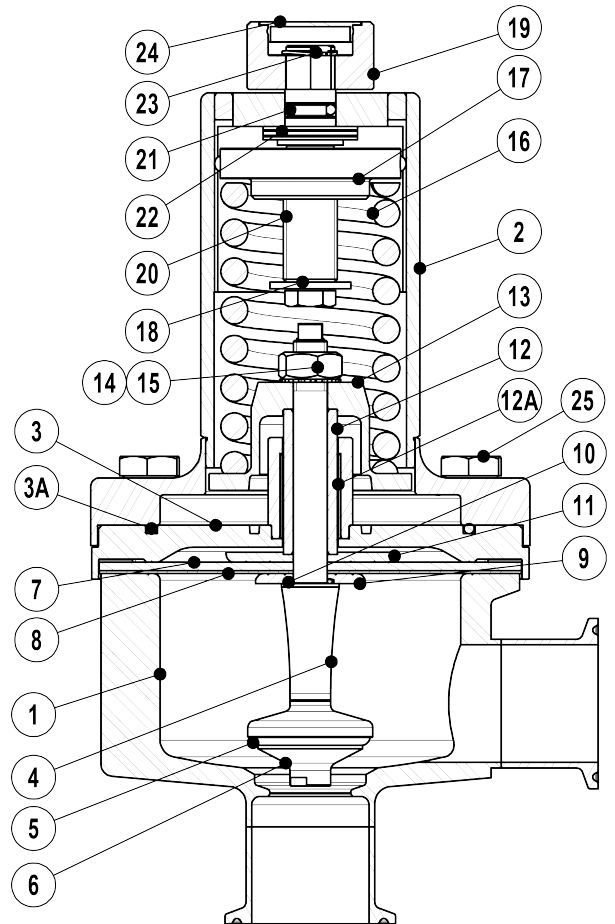

\* Available spare parts ; \*\* Others according to fluid;

\*\*\* Applied only with optional leakage line connection.

Remarks: FDA / USP Class VI seals certificate on request.

All valves have a serial number. In case of non-standard valves, this number must be supplied if spare parts are ordered.

**OPTIONS**

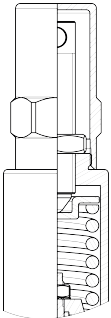
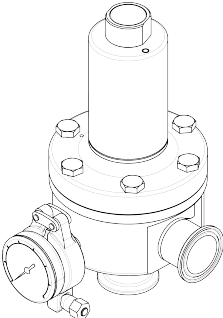
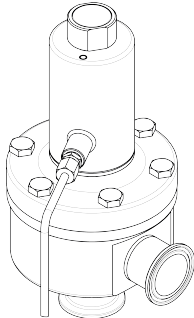
ADJUSTING SCREW W/ TOP CAP	PRESSURE GAUGE CONNECT.	LEAKAGE LINE CONNECTION
		

ORDERING CODES PS160

Valve model	PS16	4	1	T	M	I	X	X	X	DI	20	E
PS160 – AISI 316L / 1.4404 diaphragm sensing pressure sustaining valve	<b>PS16</b>											
<b>Regulating range</b>												
0,8 to 1,5 bar		4										
1 to 3 bar		5										
1,5 to 8 bar		7										
<b>Flow rate coefficient</b>												
Kvs 1,3 (3/4" – DN 20)			1									
Kvs 3,5 (1" – DN 25)			3									
Kvs 5,5 (1 1/2" – DN 40)			4									
Kvs 8,5 (2" – DN 50)			6									
<b>Diaphragm material</b>												
PTFE (Gylon)				T								
EPDM (non-standard)				E								
<b>Valve head</b>												
Metal to metal (non-standard)					M							
EPDM					E							
PTFE					T							
FPM / Viton					V							
<b>Adjustment knob, top cap and captured vent</b>												
Stainless steel adjustment knob						I						
Top cap (adjustment screw with cover)						T						
Stainless steel adjustment knob w/ diaphragm cover leakage connection in case of diaphragm failure						L						
Top cap (adjustment screw with cover) w/ diaphragm cover leakage connection in case of diaphragm failure						U						
<b>Gauge port options</b>												
Without gauge ports								X				
Tri-clamp gauge port on the left side (rel. to the flow direction) – upstream pressure								7				
Tri-clamp gauge port on the right side (rel. to the flow direction) – upstream pressure								6				
Tri-clamp gauge port on both sides – upstream pressure								5				
Threaded gauge port on the left side (rel. to the flow direction) – upstream pressure – ISO 7 Rp 1/4"								4				
Threaded gauge port on the right side (rel. to the flow direction) – upstream pressure – ISO 7 Rp 1/4"								3				
Threaded gauge port on both sides – upstream pressure – ISO 7 Rp 1/4"								2				
Threaded gauge port on the left side (rel. to the flow direction) – upstream pressure – 1/4" NPT								W				
Threaded gauge port on the right side (rel. to the flow direction) – upstream pressure – 1/4" NPT								Y				
Threaded gauge port on both sides – upstream pressure – 1/4" NPT								Z				
<b>Surface finish a)</b>												
Standard surface finish									X			
Mirror mechanical polished external surfaces (SF1)									P			
Electropolished internal wetted parts (SF5)									E			
<b>Special features</b>												
None										X		
Degreased for oxygen											O	
<b>Pipe connections</b>												
Clamp ferrule ASME BPE											D	
Clamp ferrule DIN (DIN 32676-A)											F	
Clamp ferrule ISO (DIN 32676-B)											E	
Tube weld (ETO) according to ASME BPE											DI	
Tube weld (ETO) according to DIN 11866-A (DIN 11850-2)											FI	
Tube weld (ETO) according to DIN 11866-B (ISO 1127)											EI	
<b>Size</b>												
3/4" or DN 20												20
1" or DN 25												25
1 1/2" or DN 40												40
2" or DN 50												50
<b>Special valves / Extras</b>												
Full description or additional codes have to be added in case of a non-standard combination												E

a) Consult IS PV20.00 (Technical information) for further details and other surface finish options.